



DynAmp

**BI-DIRECTIONAL
CURRENT MONITORING RELAY
MODEL BCMR-SML / 24(609mm) INCH
CHANNEL LENGTH**

**Manual Item No. 041545
Rev. I**

**Installation, Operation
and Service Instructions**

This Page is Intentionally Blank

DynAmp LLC WARRANTY

Items and components manufactured by Seller for permanent installation are warranted for two (2) years from the date of shipment.

Items and components manufactured by Seller for portable and temporary use in more than one location, are warranted to be free from defects in material and workmanship for a period of eighteen (18) months from the date of shipment.

Items and components not manufactured and resold by Seller, are warranted by their manufacturer.

Warranty repair shall be, at DynAmp's option, in the form of repair or replacement of the defective items or components. Concerning warranty repairs, DynAmp will be responsible for DynAmp provided time, material and transportation costs (shipping or travel). Actual method of warranty repair / correction will be determined by DynAmp at DynAmp's sole option. Such warranty repair shall constitute a fulfillment of all DynAmp, LLC liabilities in respect to said items and components. In no event shall DynAmp, LLC be liable for consequential damages.

Information in this document is subject to change without notice.

© 1998 DynAmp, LLC. All rights reserved.

Reproduction for purposes other than operation and service without written permission of DynAmp, LLC is strictly forbidden.

This manual includes detailed drawings, installation, operation, service and maintenance. Users should evaluate the information in the manual and their particular application. DynAmp assumes no liability for any incidental, indirect, or consequential damages arising from the use of this documentation.

While all information presented is believed to be reliable and in accordance with accepted engineering practices, DynAmp makes no warranties as to the completeness of the information.

This Page is Intentionally Blank

Symbol Identification:

General definitions of safety symbols used on equipment and manual.



Caution/Warning: Refer to accompanying documents for instructions.

Hazard Warning!



GENERAL

All installation, maintenance and service must be performed by qualified technicians who are familiar with the warnings and instructions of this manual.

The enclosure door must remain closed at all times during operation to ensure safety of personnel. Only authorized personnel or technicians should open and service the unit.

Use of the equipment in a manner not specified by the manufacturer can impair the protection provided within.

DynAmp does not assume liability for the customer's failure to comply with the rules and requirements provided in this manual.



**HAZARDOUS
VOLTAGE**

This equipment is designed to be connected to hazardous electric voltages. Ignoring the installation precautions and warnings can result in severe personal injury or equipment damage.

To avoid the risk of electrical shock or fire, the safety instructions and guidelines in this manual must be followed. The electrical specifications must not be exceeded and the unit must be installed according to directions provided.



SENSOR INSTALLATION/ REPLACEMENT

Install sensor interconnection cables in steel conduit. Make sure sensors are installed with arrows pointing in the direction of conventional current flow in the bus. If sensors must be replaced, they should be replaced as a matched set. Recalibration is required following sensor replacement.



ELECTRICAL HAZARD

To ensure that an unwanted trip does not occur when power is turned on or off, place test switches SW201 & SW202 in the OFF position during power on <or> off switching sequence.



SW201, SW202

After energizing the BCMR, make sure that switches SW201 and SW202 on pot bracket are **BOTH** in RUN position, otherwise the BCMR will not provide the desired protection. When moving switches SW201 and SW202, always pause for at least 1 second in the OFF position. The pause will prevent false trips.



TRIP SETPOINTS

Depending on ripple or noise in a given installation, the minimum reverse trip point must be greater than 5% of forward instantaneous trip setpoint in order to prevent nuisance trips.

REVISION PAGE

<u>Page</u>	<u>Revision</u>	<u>Reason For Revision</u>	<u>Date</u>
All	NEW		02/98
All	Rev A	Revise to SML configuration	08/98
15-17 19,35, dwgs i, 3	Rev B	Revised Cal procedure Sections 5-7, 5-9. Deleted Worksheet, Cal Form from body. Revised several dwgs. Renumbered pages. Reference ECO-2979.	05/99
i, 3	Rev C	Revise Warranty, Section 2.2 (NEMA 4X to Fiberglass)	01/00
i,v,ix, 29, 33	Rev D	Position of Warranty, Table of Contents & Warning, Updated Communications & Drawing Table	03/00
i,15,31,33	Rev E	Manual Title, Section 5.5 set-up form & Deleted 84B108450 from Drawing Table & added BTD103, updated Spare Parts list	05/00
31	Rev F	Revised Spare Parts List (PCB2) Was: #009101 Is: #012656	03/01
31, 33	Rev G	Revised Spare Parts List and Drawing List	04/02
vi, 4, 7, 25	Rev H	Updated Warnings, Table 3-1 Response Time & Figure 2-1, Section 6.4 updated 2.) sentence.	09/03
All	Rev I	Update to DynAmp, LLC	12/04

This Page is Intentionally Blank

TABLE OF CONTENTS

Par.	Title	Page
SECTION I SAFETY		1
1-1.	OVERVIEW	1
SECTION II DESCRIPTION		3
2-1.	APPLICATION	3
2-2.	SYSTEM COMPONENTS	3
2-3.	OUTPUTS & INDICATORS	3
2-4.	REVERSE TRIP CHARACTERISTICS	3
2-5.	FORWARD TRIP CHARACTERISTICS	5
SECTION III SPECIFICATIONS		7
SECTION IV INSTALLATION		9
4-1.	HANDLING PRECAUTIONS	9
4-2.	INSTALLATION CONSIDERATIONS	9
4-3.	SENSOR ASSEMBLY INSTALLATION	9
4-4.	SENSOR CABLE INSTALLATION	10
4-5.	CONTROL UNIT INSTALLATION	11
SECTION V CALIBRATION		13
5-1.	TERMINOLOGY AND ABBREVIATIONS	13
5-2.	WHEN TO CALIBRATE	13
5-3.	EQUIPMENT REQUIREMENTS	14
5-4.	PROTECTIVE RANGE vs. NORMAL OPERATING RANGE	14
5-5.	GETTING STARTED	14
5-6.	VERNIER DIALS ADJUSTMENT	15
5-7.	ZERO & GAIN ADJUSTMENT (PCB 2)	15
5-8.	GAIN RANGE ADJUSTMENT (PCB 2)	16
5-9.	SIGNAL OUTPUT ADJUSTMENT (PCB 2)	17
5-10.	ADJUSTING REVERSE CURRENT TRIP SETPOINT (PCB 3)	18
5-11.	ADJUSTING FORWARD TRIP SETPOINTS - LONG (PCB 3)	19
5-12.	FORWARD TRIP SETPOINT - MEDIUM (PCB 3)	21
5-13.	FORWARD TRIP SETPOINT - SHORT (PCB3)	21
5-14.	FORWARD TRIP SETPOINT - INSTANTANEOUS (PCB3)	21
5-15.	SETTING FORWARD TRIP DELAYS (PCB3)	21
SECTION VI OPERATION AND MAINTENANCE		23
6-1.	NORMAL OPERATION	23
6-2.	POWER ON/OFF SWITCH (SW301) IMPORTANT WARNING!!!	23
6-3.	RECTIFIERS AND TRIP SETPOINTS	23
6-4.	FUNCTIONAL TEST - USING SW201 & SW202	24
6-5.	VERNIER DIALS POSITION TEST & ADJUSTMENT	25
6-6.	VISUAL INSPECTION	26
6-7.	SENSOR REPLACEMENT	27
6-8.	TROUBLESHOOTING	27

SECTION VII SERVICE, PARTS, AND DOCUMENTATION	29
7-1. FIVE YEAR SERVICE	29
7-2. SERVICE ASSISTANCE AND COMMUNICATION PROCEDURES	29
7-3. SPARE PARTS ORDERS - ROUTINE OR EMERGENCY	30
7-4. RECOMMENDED SPARE PARTS*	31
SECTION VIII DRAWINGS	33

FIGURES AND TABLES

Fig .	Title	Page
Figure 2-1.	BCMR-SML System Components	4
Figure 4-1.	Sensor Installation on Bus	10
Figure 5-1.	Vernier Dial (R202, R203)	15
Figure 5-2.	Scaling and Polarity Detection Board (PCB 2)	16
Figure 5-3.	Switch S1 Location	17
Figure 5-4.	Timing Board (PCB3)	18
Figure 5-5.	SW201, SW202 Functions	19
Figure 5-6.	Forward Trip Setpoints & Delays	20
Figure 6-1.	Rectifier Ripple & Trip Circuits	24
Figure 6-2.	BCMR-SML Block Diagram	28

Table .	Title	Page
Table 3-1.	BCMR-SML Specifications*	7
Table 3-1.	BCMR-SML Specifications (continued)	8
Table 5-1.	PCB2 S1 Gain Settings	17
Table 7-1.	Spare Parts List	31
Table 8-1.	Drawing List	33

Section I

SAFETY

1-1. OVERVIEW

This equipment is designed to be connected to hazardous electric voltages. Ignoring the installation precautions and warnings can result in severe personal injury or equipment damage. The following are general guidelines that should be followed when installing, operating and servicing the BCMR-SML.

- All installation, maintenance and service must be performed by qualified technicians who are familiar with the warnings and instructions of this manual.
- Always follow all local and plant safety procedures.
- The enclosure cover must remain closed at all times during operation to ensure safety of personnel. Only authorized personnel or technicians should be allowed to open and service the unit.
- Replace fuses with correct types and values. Do not bypass the fuses or modify the electronics.
- Units are not intrinsically safe. Do not place in explosive atmospheres.
- The sensors are splash proof but are not waterproof. Do not place sensors in rain, or under water, or submerge any part of the sensor.
- Use of the equipment in a manner not specified by the manufacturer can impair the protection provided.

DynAmp does not assume liability for the customer's failure to comply with the rules and requirements provided in this manual.

This Page is Intentionally Blank

Section II

DESCRIPTION

2-1. APPLICATION

The Bi-directional Current Monitoring Relay (BCMR-SML) protects rectifiers against forward and reverse overcurrent conditions.

2-2. SYSTEM COMPONENTS

The BCMR-SML consists of:

- Fiberglass enclosure with electronics and controls
- Two Open loop Hall effect current sensors
- Interconnecting cable
- Hardware for mounting sensors on bus

2-3. OUTPUTS & INDICATORS

The following outputs and indicators are provided by the unit:

- Two normally open (N.O.) Reverse Trip relay contact sets.
- Two normally open (N.O.) Forward Trip relay contact sets.
- One auxiliary normally open (N.O.) relay contact set.
- One analog current or voltage output proportional to forward bus current.
- Power normally open (N.O.) relay contact set.
- Reverse Trip latching LED indicator.
- Forward Trip latching LED indicator.
- Power “ON” LED indicator.
- Miscellaneous LEDs on PC board assemblies (for calibration and performance verification).

2-4. REVERSE TRIP CHARACTERISTICS

If reverse bus current exceeds a user specified reverse trip setpoint, the BCMR-SML closes (2) sets of N.O. relay contacts and illuminates the Reverse Trip LED indicator. When the reverse current condition no longer exists, or is less than Reverse Trip Setpoint, the relay coil will de-energize; however, the LED indicator will remain illuminated to alert personnel that a reverse trip has occurred. The Reverse Trip LED indicator may be reset by pressing reset switch SW302. The Reverse Trip Setpoint must be at least 5% of the BCMR protective range.

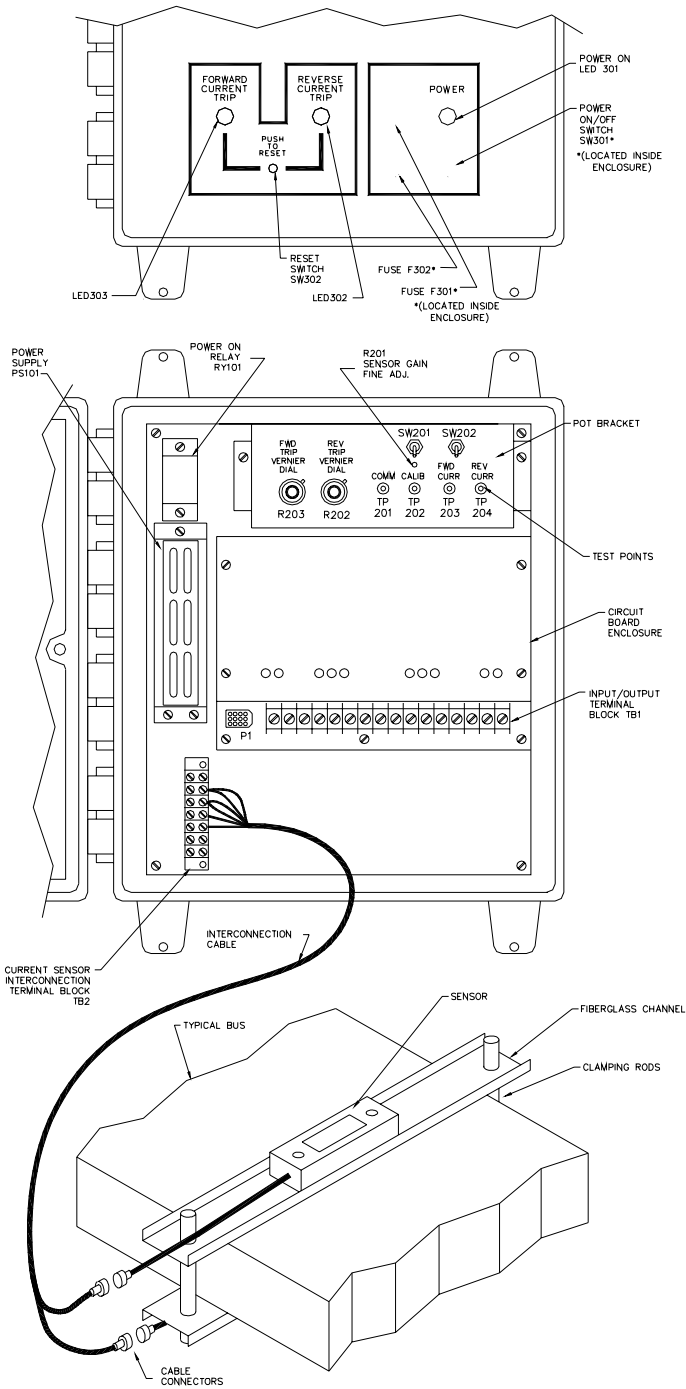

Figure 2-1.
BCMR-SML System Components

2-5. FORWARD TRIP CHARACTERISTICS

The BCMR-SML provides (4) Forward Trip Setpoints. Three of the setpoints each have an associated delay time. Each delay is adjustable from 1 millisecond to 100 seconds. The fourth forward trip is instantaneous (<10-millisecond response time). The multiple setpoint / delay arrangement allows flexibility to match forward trip characteristics to fault conditions of the process, or rectifier.

Whenever the forward rectifier current exceeds the Instantaneous Setpoint, or one of the other setpoints is exceeded for longer than its specified delay period, a forward trip occurs. The individual forward trip circuits are mathematically OR'd to energize the Forward Trip relay coil and closes (3) sets of N.O. contacts. The Forward Trip LED indicator functions in the same manner as the reverse LED described in the previous section. The Forward Trip LED indicator may also be reset by pressing the reset switch. The minimum Instantaneous Forward Trip Setpoint is 5% of protective range. Delayed trip setpoints must be "spaced at current levels no less than" 5% of the protective range to avoid false trips.

This Page is Intentionally Blank

Section III SPECIFICATIONS

**Table 3-1.
BCMR-SML Specifications***

ELECTRICAL			
Measuring Range:	±400A to 20kA dc or peak (minimum) ±4kA to 200kA dc or peak (maximum)		
Current Loop**: Output Range Burden (max)	0 to +20mA dc or peak** +10Vdc or peak		
Relay Contacts: Forward Trip Reverse Trip Power ON	All contacts: 0.5A, 125Vac / 2A, 30Vdc resistive (min.) Normally Open (N.O.) contacts (3 sets) Normally Open (N.O.) contacts (2 sets) Normally Open (N.O.) contacts (1 set)		
Indicators located on front cover: Power ON Forward Trip Reverse Trip	Red LED Yellow LED - latches after momentary trip Yellow LED - latches after momentary trip		
Indicators located on PCB 3 - Timing board (for calibration & diagnostics)	All LEDs on PCB3 are Red		
	LED	Description	ResponseTime
	1	Forward Trip - Master	<10msec
	2	Fwd. Trip Setpoint - Instantaneous	<10msec
	3	Fwd. Trip Delay - Short	10msec to 3sec
	4	Fwd. Trip Setpoint - Short	---
	5	Fwd. Trip Delay - Medium	2msec to 10sec
	6	Fwd. Trip Setpoint - Medium	---
	7	Fwd. Trip Delay - Long	8msec to 100sec
	8	Fwd. Trip Setpoint - Long	---
9	Reverse Trip - Instantaneous	<10msec	
Accuracy***	±3%		
Linearity	±2%		
Repeatability	±0.5%		
Temperature Sensitivity	±0.15%/°C		
Input Power	100 to 140Vdc 105 to 125Vac, 50/60Hz 210 to 250Vac, 50/60 Hz		
Power Consumption	75 VA		

* All general specifications are percent of full scale. Specifications subject to change without notice.

** The BCMR-SML is calibrated with (1) 500Ω resistor in the current loop; measuring across this resistor provides a 0 to +10V output (unidirectional). Removing R101 (the 500Ω load resistor) converts the output to 0 to 20mA current loop output. A 4 to 20mA current loop output is available upon request.

*** When calibrated with a DynAmp, LLC Clamp-On Portable Ammeter.

**Table 3-1.
BCMR-SML Specifications (continued)**

MECHANICAL	
Control Unit	
Enclosure Material	Fiberglass
Enclosure Dimensions	17.5H x 13.25W x 8.31D inches (7.55 x 337 x 211mm)
Weight	25lb (12kg)
Sensors	
Mounting Channel length	24 inches (610mm)****
Mounting Rod length	24 inches (610mm)****
Interconnection Cable length	100 feet (30.5m)****
ENVIRONMENTAL	
Control Unit - Ambient Temperature Range	-4° to 130°F (-20 to 55°C)
Sensors - Ambient Temperature Range	-4° to 158°F (-20 to 70°C)

**** May be cut to length during installation.

Section IV INSTALLATION

4-1. HANDLING PRECAUTIONS

Review plant safety regulations before installation.

The system should be inspected for shipping damage at the earliest opportunity. Visible damage must be reported to the carrier immediately. Concealed damage (not evident until the system is operated) must be reported to DynAmp, LLC immediately.

4-2. INSTALLATION CONSIDERATIONS

The BCMR-SML uses (2) open-loop Hall effect sensors calibrated in place to minimize the effect of external magnetic fields.

- High current fluctuations in adjacent bus bars may cause errors or false trips. If this is a problem, move the sensors away from adjacent bus and recalibrate.
- Two-way radios may also cause errors or false trips. It may be necessary to post warning signs to prevent keying of the transmitter of a two-way radio near the sensor installation.
- The sensors should be installed on a straight section of the rectifier bus, away from sharp bends in the bus and the main bus, especially if other rectifiers are feeding the bus.
- The sensors should be mounted on the two longer sides of a rectangular bus cross-section.

4-3. SENSOR ASSEMBLY INSTALLATION

Refer to drawing “Assembly, BCMR Sensor Channel” included at the end of this manual, and the figure below. Select the sensor assembly mounting location, observing the considerations given above. Install the two U channel sections as shown. Use the fiberglass rods and brass hardware supplied. Tighten the nuts on the rods to a maximum torque of 4.5 in-lbs (0.5nm) to clamp the assembly to the bus. Over tightening may strip the fiberglass rod threads.

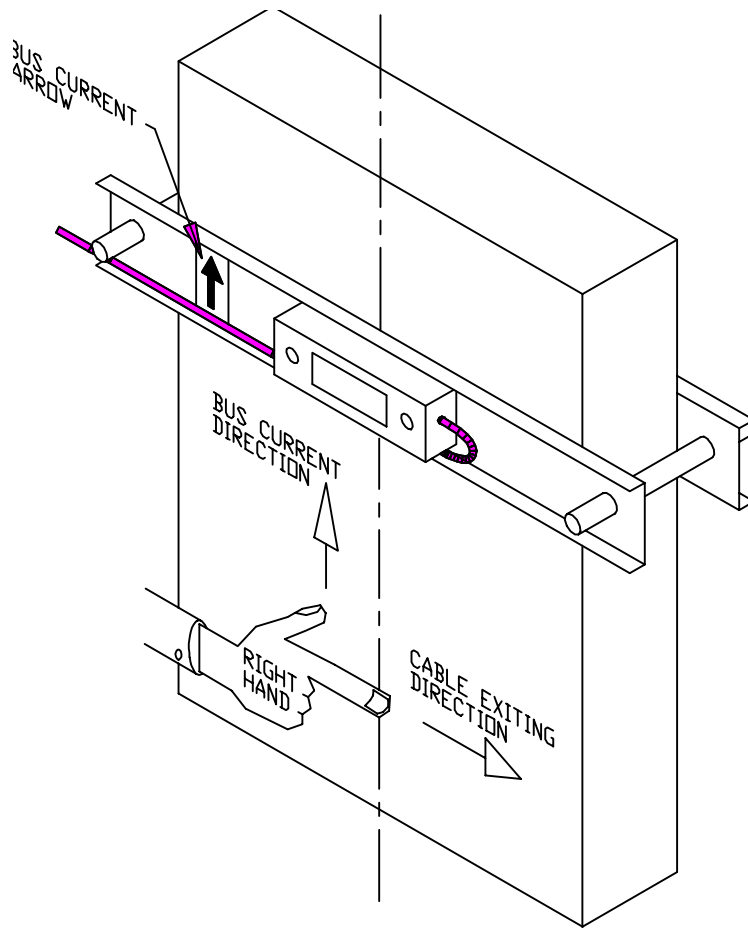

Figure 4-1.
Sensor Installation on Bus

NOTE

Be sure the arrow on each U-channel points in the direction of plus to minus (conventional) current flow. The cable lead exits from the sensors should point in opposite directions. If one sensor is reverse mounted, the signals from the sensors will cancel instead of add.

4-4. SENSOR CABLE INSTALLATION

Mate the interconnection cable with the two sensors. Either cable connector can mate with either sensor connector.

Run the interconnection cable through **steel conduit** from the sensor installation location to the control unit enclosure. This will minimize errors and false trips from magnetically coupled noise or transients. The interconnection cable will be terminated and connected in the following section.

4-5. CONTROL UNIT INSTALLATION

Refer to the Wiring Diagram, System Schematic, and Outline & Mounting Drawing at the end of this manual. Mount the enclosure as shown. Punch or drill a hole in the enclosure for wiring access. Typically ¾" steel conduit and fittings are used for this purpose. The access hole may be located on the bottom or side of the enclosure.

Make the following connections as required:

1. Cut the interconnection cable to required length, strip outer jacket 2", strip inner wires 3/16", then crimp supplied lugs on the six conductors. Connect these lugs to TB2-1, 2, 3, and 4 as shown on wiring diagram.
2. TB1-1, 2: **Input Power**. Make sure SW301 is off. Connect specified input voltage. Observe proper polarity for dc voltage inputs.
3. TB1-3, 4: **Power ON** N.O. Relay Contacts. These indicate SW1 is on and power is available to control unit. Use for remote monitoring of input power status.
4. TB1-5 (+) and TB1-6 (-): **Analog Output** is a 0 to 20 mA unidirectional current loop. A 500Ω, 0.1% precision resistor (R101) is installed across the terminals at the factory. Remove R101 for 0 to 20 mA output signal. For 0 to 10 volt output signal, the terminating resistor remains connected across TB1-5, 6. Connect wires to voltage input in parallel across R101 at TB01-5(+) and 6 (-), or locate the terminating resistor across the voltage input terminals at a remote location.

Before proceeding: Calibrate the BCMR-SML per Section V of this manual.

5. TB1-7, 8 & TB1-9, 10: Reverse **Trip** N.O. Relay contacts (2 sets). These close whenever rectifier current reverses and exceeds the reverse trip setpoint. The two contact sets may be used independently for different functions, or in parallel for increased reliability.
6. TB1-11, 12 & TB1-13, 14: Forward **Trip** N.O. Relay contacts (2 sets). These close when rectifier output exceeds the Instantaneous Forward Trip Setpoint, or when a delayed setpoint is exceeded for longer than specified timeout period. The two contact sets may be used independently for different control functions, or in parallel for increased reliability.
7. TB1-15, 16: **Auxiliary** N.O. Relay Contacts (1 set). Same as forward trip N.O. Contacts (one additional set).

This Page is Intentionally Blank

Section V CALIBRATION

5-1. TERMINOLOGY AND ABBREVIATIONS

The following terms and abbreviations are used to indicate various parameters used in calibrating and/or scaling the BCMR-SML:

FS	Full-scale (equivalent to 100% span)
FT	Forward Trip
FTS	Forward Trip Setpoint
I_{RECT FS}	<i>Rectifier Current</i> Full-scale Output (normal operating range)
LDA	DynAmp, LLC
M.A.	Manufacturer's Adjust (reference designator for scaling component values)
RT	Reverse Trip
RTS	Reverse Trip Setpoint
TCR	Temperature Coefficient of Resistance
I_{FTS}	<i>Rectifier Current</i> Forward Trip Setpoint. This includes:
I_{FTS INST}	<i>Rectifier Current</i> Forward Trip Setpoint - Instantaneous
I_{FTS LONG}	<i>Rectifier Current</i> Forward Trip Setpoint - Long Delay
I_{FTS MED}	<i>Rectifier Current</i> Forward Trip Setpoint - Medium Delay
I_{FTS SHORT}	<i>Rectifier Current</i> Forward Trip Setpoint - Short Delay
V_{FTS}	<i>Control Voltage</i> Forward Trip Setpoint. This includes:
V_{FTS INST}	<i>Control Voltage</i> Forward Trip Setpoint - Instantaneous
V_{FTS LONG}	<i>Control Voltage</i> Forward Trip Setpoint - Long Delay
V_{FTS MED}	<i>Control Voltage</i> Forward Trip Setpoint - Medium Delay
V_{FTS SHORT}	<i>Control Voltage</i> Forward Trip Setpoint - Short Delay
I_{RTS}	<i>Rectifier Current</i> Reverse Trip Setpoint - Instantaneous
V_{RTS}	<i>Control Voltage</i> Reverse Trip Setpoint
I_{RECT MEASURED}	<i>Rectifier Current</i> Measured at Time of Calibration

5-2. WHEN TO CALIBRATE

The BCMR-SML system is tested at the factory with all scaling components installed. However, the BCMR-SML **must be calibrated in place** prior to use on site. Calibration should be repeated as part of periodic equipment maintenance. DynAmp, LLC recommends a calibration period of one year for this equipment. The functions of the BCMR-SML control unit electronics may be conveniently tested using the Operation and Maintenance section of this manual. However, these functional tests do not check the function of the Hall effect sensors or system calibration accuracy. Follow steps in this section to calibrate or verify accuracy of the BCMR-SML system.

5-3. EQUIPMENT REQUIREMENTS

The following equipment is required for calibration:

Digital Multimeter (DMM):	3-1/2 digit resolution, (min.)
Clamp on Ammeter:	DynAmp Model COP or COP-D (COP-D preferred)*
Stopwatch:	0.1 second resolution

* Several other current measurement systems available from DynAmp may be substituted for Clamp on Ammeter.

5-4. PROTECTIVE RANGE vs. NORMAL OPERATING RANGE

Rectifiers may be designed to withstand current transients significantly greater than 100% normal rectifier output current. For proper setup at the factory, the rectifier full-scale output current (kA), input power, trip setpoints and delay times must be specified when the BCMR-SML is ordered. This information is typically supplied to DynAmp, LLC by the user via the “BCMR-SML Worksheet” included in the “DRAWINGS” section at the end of this manual.

The specified $I_{FTS\ INST}$ (Rectifier Current Forward Trip Setpoint - Instantaneous) level determines the full-scale **protective range** for the BCMR-SML. The normal operating range of the rectifier is typically referred to as “100% rectifier output current.” However, rectifier manufacturers and end-users may require the BCMR-SML to have protective current levels of 200% normal rectifier output current or more. The Analog Output is accessed at TB1-5(+) and TB1-6(-). This signal is proportional to the **normal operating range** of the rectifier, not the overcurrent protective range specified.

5-5. GETTING STARTED

NOTE
False trips may occur during calibration. To avoid disruptions to the process, disconnect the forward and reverse relay contacts from rectifier protection circuits until the procedure is completed.

Make sure that the unit is correctly installed, then complete the preliminary steps as follows:

1. Set the controls (on pot bracket) as follows:
 - FWD TRIP SET dial (R203) at 10.00 then lock
 - RVD TRIP SET dial (R202) at 10.00 then lock
 - SW201 switch at OFF
 - SW202 switch at OFF
2. Switch POWER ON SW301 to ON position. Confirm that the red POWER ON (LED301) is illuminated.

3. Switch SW201 and SW202 to RUN position.

Before calibrating the BCMR-SML trip setpoints and delay times, make a photocopy of BTD103, "BCMR-SML SET-UP FORM" in the drawings section of the manual. On the photocopy, specify and calculate values for $I_{RECT FS}$ (Rectifier Full-scale Output Current), Analog Output type, Trip Setpoint Currents, Trip Setpoint Voltages, and Trip Delay Times. The form includes the necessary equations to calculate trip voltages required for proper calibration.

NOTE
Trip setpoints and delay times must be determined from rectifier or diode manufacturers' specifications.

5-6. VERNIER DIALS ADJUSTMENT

Vernier Dials R203 and R202 set the control voltages present at TP203 and TP204 respectively. These voltages should each vary from 0 - 10V corresponding to Vernier full counterclockwise (0.00) and full clockwise (10.00).

To verify Vernier calibration: Observe and record position and indication of Vernier controls R203 (FWD TRIP) and R202 (REV TRIP). Connect a DMM set on volts to TP203 (+) FWD and TP201 (-). Confirm that measured voltage is within 0.02V of Vernier position. If necessary, adjust P6 on PCB3 to produce a voltage reading corresponding to Vernier position.

Connect the DMM (+) to TP204 REV. Confirm that measured voltage is within 0.02V of Vernier position. If necessary, adjust P8 to produce voltage reading corresponding to Vernier position.

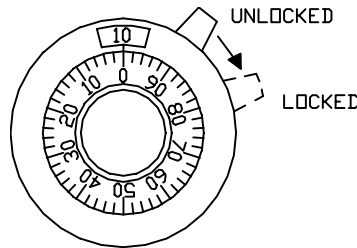

Figure 5-1.
Vernier Dial (R202, R203)

5-7. ZERO & GAIN ADJUSTMENT (PCB 2)

Refer to the figure "Scaling and Polarity Detection Board (PCB2)" and proceed as follows:

- 1.) Ensure that the sensors are installed in the proper position on the bus and are connected to the control unit.
- 2.) Reduce current in the bus to zero. Confirm that all other nearby rectifier buses or main buses are operating at normal current levels.

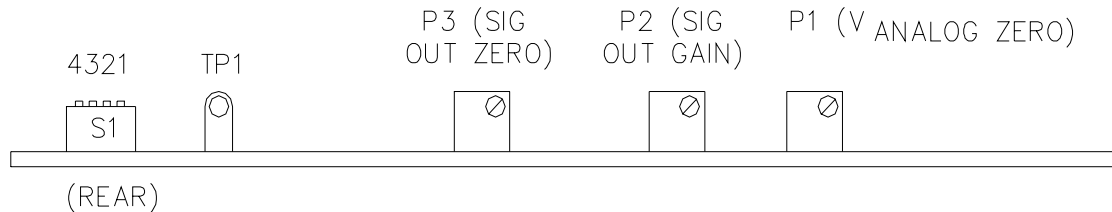

Figure 5-2.
Scaling and Polarity Detection Board (PCB 2)

- 3.) Connect the DMM to TP201 COMM (-) and TP202 CALIB (+) With the DMM on its lowest scale; adjust P1 on PCB 2 for a reading of 0.00Volts, $\pm 10\text{mV}$.
- 4.) Return current in rectifier to normal operating level. Allow at least 30 minutes for equipment temperature to stabilize. Measure and record the rectifier output current with a clamp on ammeter (or equivalent DynAmp Current Metering System). For best calibration accuracy, assure that bus current remains constant.
- 5.) Calculate the analog output voltage corresponding to the rectifier current just measured.

$$V_{\text{ANALOG}} = \frac{I_{\text{RECT MEASURED}} \text{ (kA)}}{I_{\text{FTS INST}} \text{ (kA)}} \times 10\text{V}$$

- 6.) Adjust the CALIB potentiometer (R201) for a reading equivalent to V_{ANALOG} .
- 7.) Immediately measure the rectifier current to confirm no change in bus current has occurred.
- 8.) If the rectifier output current has changed, repeat steps 4.) through 7.) as necessary.

If V_{ANALOG} is not within adjustment range of CALIB potentiometer, proceed to the following section; otherwise skip the following section.

5-8. GAIN RANGE ADJUSTMENT (PCB 2)

BCMR-SML sensor output voltage levels vary depending on sensor mounting location on the bus. In some cases, the MED LOW gain range is not sufficient drive V_{ANALOG} as required. The sensor signal input amplifier gain range may be adjusted via switch S1 on PCB2. This allows use of R201 CALIB potentiometer for fine gain adjustment (as discussed in the previous section).

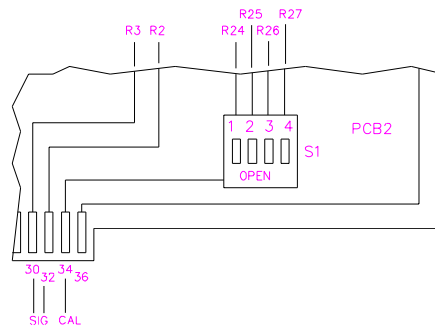

**Figure 5-3.
Switch S1 Location**

Gain Range	PCB2 S1	PCB2 S2	PCB2 S3	PCB2 S4
Low	X	0	0	0
Med. Low	0	X*	0	0
Med. High	0	0	X	0
High	0	0	0	X

*As shipped from factory

X = Closed

0 = Open

**Table 5-1.
PCB2 S1 Gain Settings**

To change gain range, turn the POWER switch to OFF and remove PCB 2 from the card rack. Refer to the table “PCB2-S1 Gain Settings”, then set S1 as required. After changing settings of PCB2-S1, PCB2-P1, -P2, and -P3 must be readjusted.

5-9. SIGNAL OUTPUT ADJUSTMENT (PCB 2)

The signal output is unidirectional and may not be used to measure reverse bus current. For forward bus current, the signal output may be configured as a current loop or voltage output. The BCMR-SML is supplied with a 500Ω terminating resistor connected across TB1-5 and TB1-6. R101 is a 500Ω 0.1% tolerance, ½ watt, with 25 ppm/°C temperature coefficient of resistance. The full-scale output voltage scaling may be adjusted to a lower FS voltage level by changing the terminating resistor value and / or recalibrating the output. The resistor used for R101 should be 1% tolerance, ½ watt (or greater) with a temperature coefficient of 100 ppm/°C (minimum).

To calibrate the signal output:

1. Reduce current in the bus to zero. Confirm that all other nearby rectifier buses or main buses are operating at normal current levels.

2. Refer to Figure "Scaling and Polarity Detection Board - PCB2".
3. For a current loop output, remove terminating resistor R101 across TB1-5 and TB1-6. Connect the DMM's mA input to TB-5 (+) and TB-6 (-). Adjust PCB2-P3 for specified mA current at zero bus current (typical values: 0mA, or 4mA).
4. For 0 to 10V output, measure the voltage drop across the 500Ω resistor connected to TB1-5 (+) and TB1-6 (-). Terminating resistor R101 may be connected across voltage input terminals located at a distance from the Control Unit. Also, a lower value resistor may be substituted for R101 to scale the output for spans less than 10V full-scale.
5. Adjust PCB2-P3 for specified voltage output at zero bus current (default setting: 0V at FS bus current).
6. Calculate $I_{SIG\ OUT}$ as follows: $I_{SIG\ OUT} = \{I_{RECT\ MEA} (kA) / I_{RECT\ FS} (kA)\} \times 20mA$.
7. Calculate $V_{SIG\ OUT}$ as follows: $V_{SIG\ OUT} = \{I_{RECT\ MEA} (kA) / I_{RECT\ FS} (kA)\} \times 10V$.
8. Set bus current to full-scale (FS) operating level.
9. For current loop output: adjust PCB2-P2 for calculated $I_{SIG\ OUT}$ at FS bus current.
10. For voltage output: adjust PCB2-P2 for calculated $V_{SIG\ OUT}$ at FS bus current.

5-10. ADJUSTING REVERSE CURRENT TRIP SETPOINT (PCB 3)

The Instantaneous Forward Trip Setpoint ($I_{FIS\ INST}$) determines the BCMR-SML **forward and reverse protective ranges**. The Reverse Trip Setpoint is set using the Reverse Trip Vernier dial (R202) mounted on the pot bracket. The Vernier dial position is ratiometric, with full clockwise (10.0 position) corresponding to 100% of the protective range; full counterclockwise (0.0 position) corresponds to 0% of protective range.

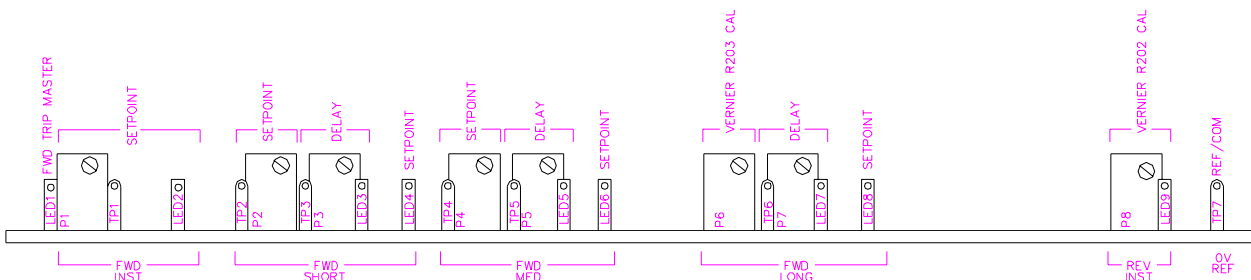

Figure 5-4.
Timing Board (PCB3)

To set the Reverse Trip Setpoint: $V_{RTS\ INST} = 200mV\ min$.

- 1.) Calculate and record $V_{RTS\ INST}$ (200mV min, 10V max). $I_{RTS\ INST}$ must be high enough to produce $V_{RTS\ INST} \geq 200mV$. (See BCMR calibration formula.)
- 2.) Connect the DMM on volts setting between TP204 REV CURR 4(+) and TP201 COM (ref) test points on the pot bracket.
- 3.) Rotate R202 (Reverse Trip Vernier) to appropriate position to produce desired Reverse Trip Setpoint. Lock Vernier control R202.
- 4.) Observe LED 9 on PCB 3 and move switches SW201 and SW202 to Rev. test position per SW201, SW202 function table below. The REVERSE CURR TRIP LED (LED302) should be illuminated.









	SW201	SW202
FWD. TEST		
REV. TEST		
OFF		
RUN		

Figure 5-5.
SW201, SW202 Functions

- 5.) Move the SW202 switch to RUN (pausing at OFF). Now LED 9 should go out. The Reverse Current Trip LED302 should still be on.
- 6.) Depress and release the PUSH TO RESET switch on the door; LED302 should go out.

5-11. ADJUSTING FORWARD TRIP SETPOINTS - LONG (PCB 3)

Using rectifier manufacturers' specifications, determine $I_{FTS\ LONG}$, the lowest level at which a forward trip is to occur. This setpoint will have the longest delay time. The medium, short, and instantaneous Forward Trip Setpoints are referenced to the long Forward Trip Setpoint. This produces relative tracking of all trip setpoints via adjustment of R203 Vernier control.

Refer to the figure below.

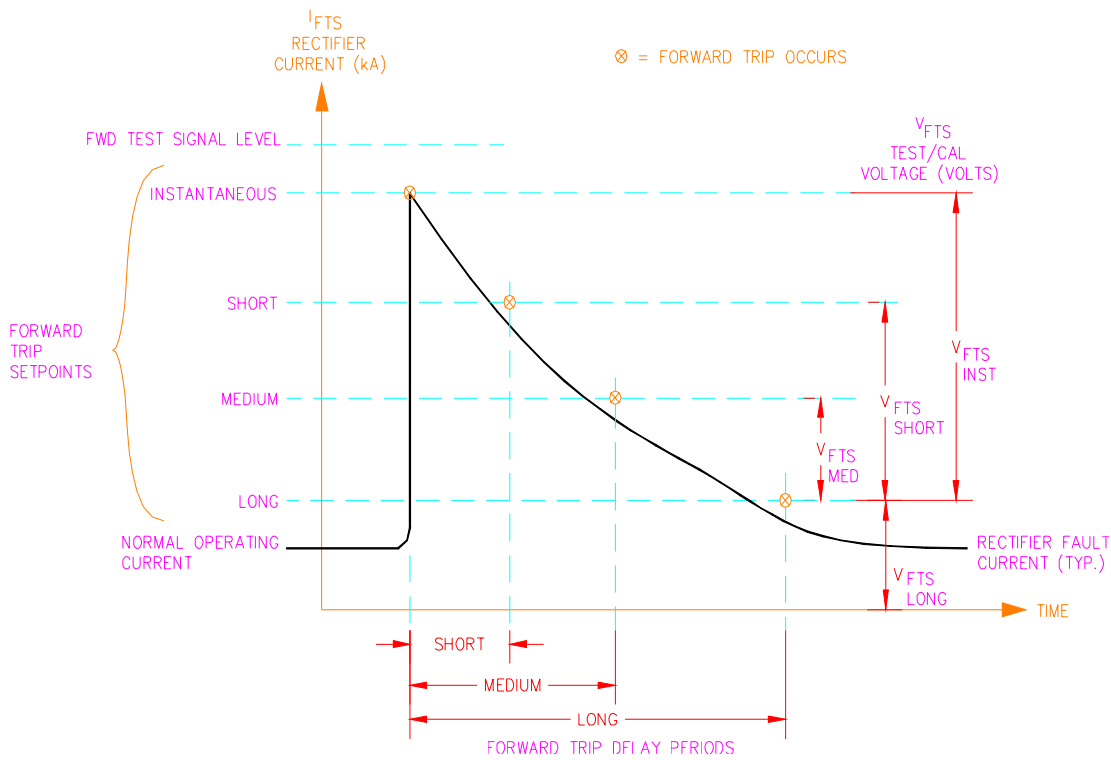

Figure 5-6.
Forward Trip Setpoints & Delays

To set $I_{FTS\ LONG}$ (Forward Trip Setpoint Long Delay):

Calculate and record $V_{FTS\ LONG}$ on the BCMR-SML Calibration Form.

$$V_{FTS\ LONG} = 10V \times \frac{I_{FTS\ LONG} \text{ (kA)}}{I_{FTS\ INST} \text{ (kA)}}$$

1. Adjust R203 FORWARD CURR TRIP SET Vernier so that dial reading corresponds to the calculated $V_{FTS\ LONG}$ value. Lock the dial.
2. Connect a DMM set on volts across PCB3-TP1 (+) and PCB3-TP7 (-).
3. Adjust PCB3-P6 to produce a reading of $V_{FTS\ LONG}$, as determined from rectifier specifications.
4. Measure and record voltage at PCB3-TP1.

5-12. FORWARD TRIP SETPOINT - MEDIUM (PCB 3)

1. Calculate and record the medium setpoint voltage on the Calibration Form:

$$V_{F\text{TS MED}} = 10\text{V} \times \frac{\{ I_{F\text{TS MED}}(\text{kA}) - I_{F\text{TS LONG}}(\text{kA}) \}}{I_{F\text{TS INST}}(\text{kA})}$$

2. Refer to figure called “BCMR PCB3”. Connect a DMM set for volts between PCB3-TP4 (+) and PCB4-TP7 (-). Adjust PCB3-P4 to produce a reading equal to V_{F_{TS} MED} (+0.02V).

5-13. FORWARD TRIP SETPOINT - SHORT (PCB3)

1. Calculate and record the short setpoint voltage on the Calibration Form:

$$V_{F\text{TS SHORT}} = 10\text{V} \times \frac{\{ I_{F\text{TS SHORT}}(\text{kA}) - I_{F\text{TS LONG}}(\text{kA}) \}}{I_{F\text{TS INST}}(\text{kA})}$$

2. Refer to figure called “BCMR PCB3”. Connect a DMM set for volts between PCB3-TP2 (+) and PCB4-TP7 (-). Adjust PCB3-P2 to produce a reading equal to V_{F_{TS} SHORT} (+0.02V).

5-14. FORWARD TRIP SETPOINT - INSTANTANEOUS (PCB3)

1. Calculate and record the instantaneous setpoint voltage on the Calibration Form:

$$V_{F\text{TS INST}} = 10\text{V} \times \frac{\{ I_{F\text{TS INST}}(\text{kA}) - I_{F\text{TS LONG}}(\text{kA}) \}}{I_{F\text{TS INST}}(\text{kA})}$$

2. Refer to figure called “BCMR PCB3”. Connect a DMM set for volts between PCB3-TP1 (+) and PCB4-TP7 (-). Adjust PCB3-P1 to produce a reading equal to V_{F_{TS} SHORT} (±0.02V).

5-15. SETTING FORWARD TRIP DELAYS (PCB3)

This adjustment requires a stopwatch and DMM. Remember to pause when switching through the OFF position of switches SW201 and SW202.

Long Delay

- 1.) Refer to figure “Timing Board (PCB3)”. Move switches SW201 and SW202 in RUN position.

- 2.) Simultaneously start the stopwatch and move SW201 to FWD TEST position (Note: SW202 position does not change). LED 8 should immediately come on.
- 3.) Observe LED 7 and stop the stopwatch count when it comes on; then move SW201 to RUN position.
- 4.) Adjust PCB3-P7 to change the delay time (time between LEDs 7 and 8 coming on) to specified trip delay time.
- 5.) Repeat steps above until the desired trip delay time is achieved.
- 6.) Measure and record the voltage at PCB3-TP6. For future calibration, the same delay period can be obtained by adjusting P7 for this trip delay voltage.

Medium Delay Circuit

Adjust the delay time for the medium delay using the same method as for long delay above. Note the differences:

- LED 6 will come on when SW201 is switched.
- LED 5 will come on when medium delay has timed out.
- TP5 adjusts delay time.
- Trip delay (+) voltage measured at PCB3-TP5.

Shortest Time Delay Circuit

Use the same technique as above for the short delay. Note the following differences:

- LED 4 will come on immediately when SW201 is switched.
- LED 3 will come on when short delay has timed out.
- P3 adjust delay time.
- Trip delay voltage (+) measured at PCB3-TP3.

Disconnect all test equipment. Move SW201 and SW202 in the OFF position, pause, and then place them in the RUN position. Reset the CURRENT TRIP lamp(s) on the door as required.

NOTE
Be sure to reconnect all protective devices to the terminals of the forward and reverse relays after this procedure is completed.

SECTION VI OPERATION AND MAINTENANCE

6-1. NORMAL OPERATION

During normal operation the control unit door should be closed and secured by tightening the crews on the door latches. This will prevent tampering or accidental use of switches and trip setpoint controls. The POWER SWITCHED terminals (TB1-1, 2) should be connected to a monitor or alarm device, in a control area, so that it will be known immediately if the POWER switch is turned off or if input power to the unit is down. It is normal for the output of the BCMR to change during warm-up of the rectifier system. The BCMR-SML is calibrated with bus on, at working conditions; the effects of change due to temperature are minimized.

6-2. POWER ON/OFF SWITCH (SW301) IMPORTANT WARNING!!!

Before SW301 POWER switch is changed from OFF to ON, or vice versa, SW201 and SW202 switches must be placed at OFF (center position). After SW301 is turned on, be sure that SW201 and SW202 are **BOTH** placed in the RUN position. This procedure will ensure that an unwanted trip of the forward and reverse relays does not occur when using the POWER ON switch (especially during power “turn on cycle”).

6-3. RECTIFIERS AND TRIP SETPOINTS

Rectifier current waveforms vary with the number of phases used to achieve rectification, filtering, and load.

The output waveform usually consists of a dc component and an ac component (ripple). This output is usually read with an average reading dc meter. This method gives a good overall indication of the rectifier’s performance for most applications. The ac component (ripple) of the dc value can be read with an ac coupled ac meter. This reading is helpful for setting the BCMR-SML, trip setpoints; however, the peak-to-peak value of ripple (measured with an oscilloscope) is the preferred means of determining trip setpoints.

Values of ripple current will vary with load and may be very large in a short circuit condition. The trip setpoint values should be set far enough apart from each other so as not to get any interaction, typically twice the value of the normal peak-to-peak ripple value. This value can be measured at test points TP201 (-) and TP202 (+) once the BCMR-SMLs scaling board is calibrated. This should be done with an oscilloscope. The figure below shows the difference between instantaneous and delayed forward trip setpoints with respect to ripple on the rectifier output.

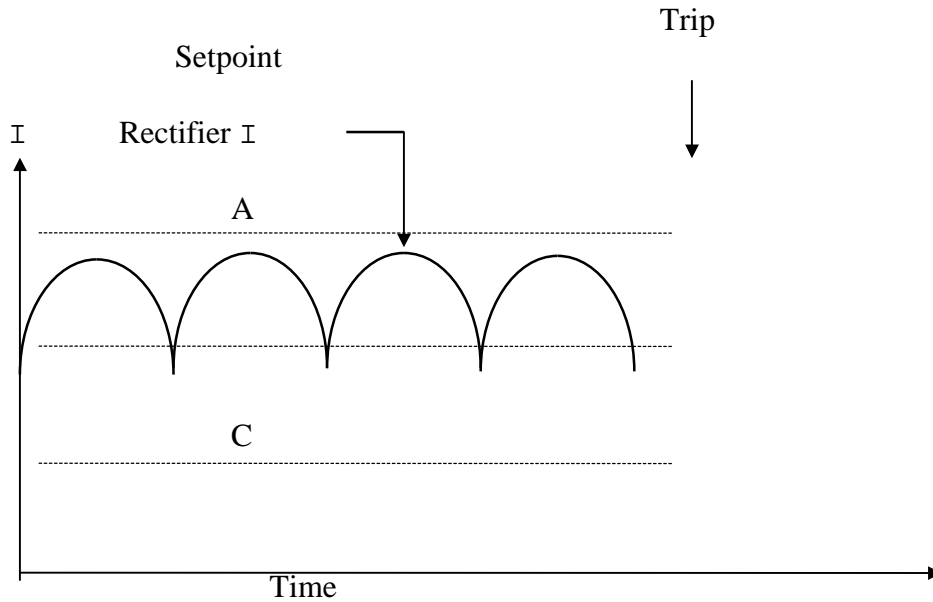

Trip Setpoint	Setpoint LED (PCB3)	Instantaneous Trip Status	Delayed Trip Status
A	Off	No Trip	No Trip
B	Dimly Lit	No Trip	Trip
C	On	Trip	Trip

**Figure 6-1.
Rectifier Ripple & Trip Circuits**

6-4. FUNCTIONAL TEST - USING SW201 & SW202

The FWD and REV TEST functions should be performed periodically to assure proper equipment function. Switches SW201 and SW202 provide a complete checkout of the circuitry, except for the sensors and any external control or protection devices connected to the forward and reverse relay contacts. Relays operate during a test cycle; however, the contacts are electrically switched to disconnect from TB1 outputs. Therefore, external alarm devices are not initiated during testing.

CAUTION

To ensure that an unwanted trip does not occur, allow a slight pause at the OFF position when switching from RUN to TEST or from TEST to RUN. This allows relay contacts to be switched open from external alarm device connections at TB1.

The TEST functions are accomplished as follows:

- 1.) Open the door on the control unit and locate the LEDs on PCB 3 (see drawing of PCB 3 in figure 4-3).

WARNING
Hazardous voltages may exist at terminal-strip contacts TB-1 through TB-16. Whenever the control unit door is open, exercise caution to avoid touching these points.

- 2.) Place switches SW201 and SW202 to OFF (pause), then to FWD TEST positions. Confirm that LEDs 2, 4, 6, and 8 (PCB 3 setpoint LEDs) light immediately. Then, as their respective time delay periods are reached, LEDs 3, 5, and 7 should light. As soon as the first of those LEDs lights, LED 1 should come on and the forward relay coil will energize, causing the LED303 (FORWARD CURRENT TRIP) (on the door) to be illuminated.
- 3.) Place switches SW201 and SW202 to OFF (pause), then to RUN. All LEDs that were illuminated should now be off. LED303 (FORWARD CURRENT TRIP) should still be illuminated. Depress and release SW302 (PUSH TO RESET switch) and LED303 will go out.
- 4.) Locate LED 9 on PCB 3.
- 5.) Place switches SW201 and SW202 to OFF (pause), then to REV TEST positions. LED 9 should illuminate immediately, and the reverse relay should actuate, causing LED302 (REVERSE CURRENT TRIP on the door) to light.
- 6.) Place the SW201 and SW202 to OFF (pause), then to RUN (fully down); LED 9 will go out, but the LED302 lamp will remain illuminated.
- 7.) Depress and release SW302 (PUSH TO RESET switch). LED302 will go out. Close and secure the door. This completes the normal test routine.

If the functions above do not occur as described, repeat to verify malfunction. If the condition persists, proceed to troubleshoot the unit.

6-5. VERNIER DIALS POSITION TEST & ADJUSTMENT

Vernier Dials R202 and R203 control the voltage present at TP204 and TP203 respectively. These voltages should each vary from 0 - 10V corresponding to Vernier full counterclockwise (0.00) and full clockwise (10.00).

To verify Vernier calibration: Observe and record position and indication of Vernier controls R203 (FWD TRIP) and R202 (REV TRIP). Connect a DMM set on volts to TP203 (+) FWD and TP201 (-). Confirm that measured voltage is within 0.02V of Vernier position. If necessary, adjust P6 on PCB3 to produce a voltage reading corresponding to Vernier position.

Connect the DMM (+) to TP204 REV. Confirm that measured voltage is within 0.02V of Vernier position. If necessary, adjust P8 to produce voltage reading corresponding to Vernier position.

6-6. VISUAL INSPECTION

Visually inspect the items listed and correct any problems discovered.

- 1.) Sensor Assembly. Check the fiberglass channels and rods for cracks or damage. Check the sensors to ensure that they are securely mounted in the channels. Disconnect the sensor connectors and check for corrosion; clean as required and reconnect.

WARNING
Even with SW301 (POWER switch) off, hazardous voltages may exist on the main terminal strip. Whenever the control unit door is open, exercise caution to avoid touching the terminal strip.

- 2.) Control Unit. Turn switch SW301 (POWER switch) off. Check all terminal connections to make sure they are tight and free of corrosion. Check all input and output wiring for damage or loose connections or damaged insulation.
- 3.) Check the wiring of door components for damage or loose connections.
- 4.) Remove all plug-in PC boards. Check for evidence of component damage, overheating, etc. Check foil paths for cracks or separation from the board. Check contact fingers for corrosion and clean as required.
- 5.) Check traces and connectors on the mother board as above. Check the board-mounting hardware and PC guides to make sure they are secure.
- 6.) Reinstall all PC boards and turn the POWER switch on.

NOTE
At this point, refer to CALIBRATION section of this manual to recalibrate the BCMR-SML and complete the periodic maintenance.

6-7. SENSOR REPLACEMENT

If it becomes necessary to remove a sensor, be sure to replace it on the fiberglass channel in the proper orientation. (Refer to figure 4-1 “Sensor Installation on Bus”). The orientation of the sensor with respect to the bus and its current follows a right hand rule. If the thumb of the right hand points in the direction of current flow (plus to minus) and the smaller fingers are positioned as if to curl around the center line of the bus as shown, the index finger will point in the proper exiting direction for the sensor cable.

6-8. TROUBLESHOOTING

If the BCMR-SML does not appear to be functioning properly, troubleshoot as follows:

- 1.) Refer to the Block Diagram below and schematics at the rear of this manual.
- 2.) Check all fuses. Replace only with same type and current rating.
- 3.) Turn power ON and measure DC power supply voltages. Connect DMM set on volts to TB2-1 (+15V) and TB2-5 (0V - common). Reading should be between +14.8V and +15.2V. Connect DMM (+) to TB2-2 (-15V). Reading should be between -14.8V and -15.2V. Replace power supply if necessary.
- 4.) Substitute spare, known good PC board assemblies for PCB 2,3, and 4.

Once a problem is isolated to a particular board, the spare boards restores operation and the faulty board may be repaired by a qualified service technician or returned to DynAmp for repair.

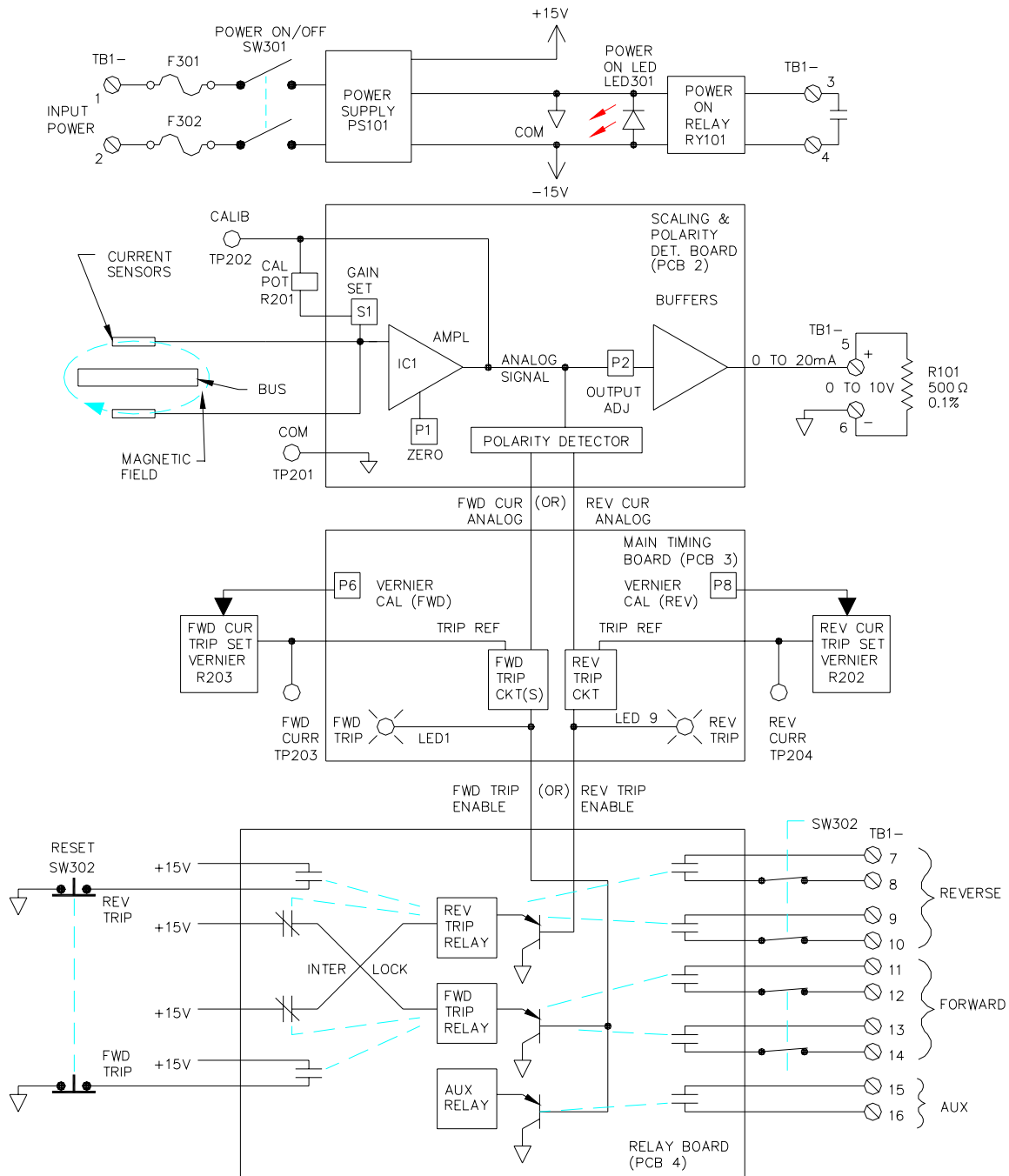

Figure 6-2.
BCMR-SML Block Diagram

Section VII

SERVICE, PARTS, AND DOCUMENTATION

7-1. FIVE YEAR SERVICE

Since electrolytic capacitors have a tendency to deteriorate with time, DynAmp, LLC recommends they be changed after five years, to ensure continued reliability of the Signal converter.

7-2. SERVICE ASSISTANCE AND COMMUNICATION PROCEDURES

If operational problems arise which can not be resolved by review of all procedures given in this book, please contact "Service" at DynAmp, LLC:

NORMAL BUSINESS HOURS: 8:00 am to 4:15 PM, USA EASTERN TIME ZONE, *
Monday through Friday.

*Greenwich Mean Time, normal working hours Monday through Friday:

From last Sunday in October to 1st Sunday in April; 13:00Z to 21:15Z

From 1st Sunday in April to last Sunday in October; 12:00Z to 20:15Z

TELEPHONE 614-871-6900: Our automated answering service will accept your messages at all off-hours including weekends. Phone in and follow instructions for non-emergency service. We receive those messages at 8 am on the next normal workday. We will respond at the earliest time possible, within your time zone and normal workday.

FACSIMILE 614-871-6910: Automatic reception during all hours.

NOTE

If you are experiencing downtime or other circumstances that are truly critical during our off-hours (see above), and wish to telephone us, please telephone at 614-871-6900 and follow the instructions for **EMERGENCY SERVICE**. You will be contacted within 30 minutes. We cannot, however, guarantee that service assistance will be available at any given off-hour time.

When we are reached by phone, our first step will be to provide over-the-phone assistance, at no charge. If the problem cannot be resolved by telephone, we will arrange for service at your site or by shipment to DynAmp, LLC, as you request. We will make every possible attempt to quickly support your emergency, on-site needs, regardless of how contacted.

7-3. SPARE PARTS ORDERS - ROUTINE OR EMERGENCY

Requests for spare parts, either in an emergency or for a routine order, should be directed to “Inside Sales” at DynAmp, LLC during normal hours, if possible, or via any method shown above for off-hours. When contacting us, please present as much information as possible; the related equipment Model Number and Serial other identifying or vendor number (s); and your time needs. An approved Purchase Order Number should be given with your order.

7-4. RECOMMENDED SPARE PARTS*

The following table lists the minimum recommended quantities for spare parts for the BCMR-SML. As spares are used, replacements should be ordered. Since continuous operation of protective electronics in high-current rectifiers is usually critical, stocking spare parts should be given high priority.

**Table 7-1.
Spare Parts List**

DESCRIPTION	ITEM NO.	QUAN.
1 to 3 units:		
Fuse, AGC1/2 (F301 & F302)	001675	4
LED, Red 24V Panel Mount	041916	1
LED, Yellow 24V Panel Mount	041917	1
Relay, 12Vdc 30A Panel Mount	041915	1
PCB2, Scaling and Polarity Detector	012656	1
PCB3, Timing PCB	017224	1
PCB4, Relay Board	010356	1
Assembly, Sensor/Channel Pair	042389	2
Power Supply*	see below	1
4 to 10 units		
Fuse, AGC1/2	001675	6
LED, Red 24V Panel Mount	041916	2
LED, Yellow 24V Panel Mount	041917	2
Relay, 12Vdc 30A Panel Mount	041915	2
PCB2, Scaling and Polarity Detector	012656	2
PCB3, Timing PCB	017224	2
PCB4, Relay Board	010356	2
Assembly, Sensor/Channel Pair	042389	4
Power Supply*	see below	2
11 or more units:		
Fuse, AGC1/2	001675	12
LED, Red 24V Panel Mount	041916	3
LED, Yellow 24V Panel Mount	041917	3
Relay, 12Vdc 30A Panel Mount	041915	3
PCB2, Scaling and Polarity Detector	012656	3
PCB3, Timing PCB	017224	3
PCB4, Relay Board	010356	3
Assembly, Sensor/Channel Pair	042389	6
Power Supply*	see below	3

* Select appropriate power supply:

DESCRIPTION	ITEM NO.
Power Supply, Input: 85 to 140Vdc / Output: ± 15 Vdc	041880
Power Supply, Input: 90 to 132Vac / Output: ± 15 Vdc	041918
Power Supply, Input: 180 to 264Vdc / Output: ± 15 Vdc	041922

* For one to five units, stock the quantities shown. For six or more units, a complete system (Head, cable, and Signal converter) should be kept on hand.

** All fuses 250V; 1¼" X ¼" (32mm X 6.5mm) type 3AB.

This Page is Intentionally Blank

Section VIII DRAWINGS

The drawings listed in table 8-1 have been included in the rear of this manual.

**Table 8-1.
Drawing List**

DRAWING TITLE	NUMBER
Assembly: BCMR-SML Control Unit Panel	84C108081
Assembly: BCMR-SML Control Unit	84C108213
Assembly: BCMR-SML Sensor Board	26A104018
Assembly: BCMR-SML Potentiometer Bracket	84C108080
Assembly: BCMR-SML Backplane	26B108215
Assembly: BCMR-SML PCB2 (Scaling & Polarity Detector)	26A103110
Assembly: BCMR-SML PCB3 (Main Timing Board)	26A104139
Assembly: BCMR-SML PCB4 (Relay Board)	26A102508
Schematic: BCMR-SML Sensor Board	05A104019
Schematic: BCMR-SML PCB2 (Scaling & Polarity Detector)	05A103109
Schematic: BCMR-SML PCB3 (Main Timing Board)	05B104135
Schematic: BCMR-SML PCB4 (Relay Board)	05A102223
Schematic: BCMR-SML System	05D108198
Outline & Mounting: BCMR Sensor / Channel Assy	02A108449
Outline & Mounting: BCMR-SML (Enclosure)	02C104874
Sensor Channel Mounting Dimensions	89B042388
Wiring: BCMR-SML Control Unit	83C108084
Wiring: BCMR-SML Potentiometer Bracket	83B108079
BCMR-SML Set-up Form	BTD103