



DynAmp

## **LKCO Series**

# **Fiber Optic High Current Measurement System Installation, Operation and Service Manual**

**Manual Item No. 045047**

**Rev. H**



**This Page is Intentionally Blank**

## **DYNAMP, LLC WARRANTY**

Items and components manufactured by DynAmp, LLC for permanent installation are warranted to be free from defects in material and workmanship for a period of two (2) years from the date of shipment.

Items and components manufactured by DynAmp, LLC for portable and temporary use in more than one location are warranted to be free from defects in material and workmanship for a period of eighteen (18) months from the date of shipment.

Extended warranties may be available for purchase for some products. Extended warranties are provided on a serial number by serial number basis as noted on DynAmp's original invoice and/or packing list.

Items and components not manufactured and resold by DynAmp, LLC are warranted by their manufacturer.

Warranty repair shall be, at DynAmp's option, in the form of repair or replacement of the defective items or components. Concerning warranty repairs, DynAmp, LLC will be responsible for DynAmp provided time, material and transportation costs (shipping or travel). Actual method of warranty repair / correction will be determined by DynAmp, LLC at DynAmp's sole option. Such warranty repair shall constitute a fulfillment of all DynAmp, LLC liabilities in respect to said items and components. In no event shall DynAmp, LLC be liable for consequential damages.

Information in this document is subject to change without notice.

© 2005, 2008, 2010, 2011, 2012, 2014, 2016, 2019 DynAmp, LLC. All rights reserved.

Reproduction in any manner whatsoever for purposes other than installation, operation, or service by the purchaser or end user without the written permission of DynAmp, LLC is strictly forbidden.

This manual is part of the complete set of product documentation that includes installation, operation, and service instructions, drawings and test results. Users should evaluate the information in the context of the complete set of product documentation and their particular applications. DynAmp, LLC assumes no liability for any incidental, indirect, or consequential damages arising from the use of this documentation.

While all information presented is believed to be reliable and in accordance with accepted engineering practices, DynAmp, LLC makes no warranties as to the completeness of the information.

All trademarks used in association with LKCO are trademarks of DynAmp, LLC.

**This Page is Intentionally Blank**

LKCO Series Fiber Optic High Current Measurement Systems conform to the latest European directives and standards concerning safety and electromagnetic compatibility.

Application of Council Directive(s):

73/23/EEC, 89/336/EEC and 93/68/EEC.

Standards to which conformity is declared:

Electromagnetic Compatibility: Immunity ( 61000 - 4-2; 4-3, 4-4, 4-6, 4-8, 4-11 )  
Emissions ( 55011; 61000 – 3-2, 3-3 )

Safety Standards:

EN 61010-1: Safety Requirements for Electrical Equipment for Measurement, Control, and Laboratory Use.



Note :

According to EN 50082, the manufacturer must state the degradation of performance level acceptable during immunity tests. Unless otherwise noted in the manual or data sheet, DynAmp limits degradation during immunity tests for this equipment to < 0.5% FS for A-criterion tests.

**This Page is Intentionally Blank**

**TABLE OF CONTENTS**

<u>Paragraph</u>	<u>Title</u>	<u>Page</u>
	<b>DYNAMP, LLC WARRANTY</b>	<b>III</b>
	<b>TABLE OF CONTENTS</b>	<b>VII</b>
	<b>INTRODUCTION</b>	<b>IX</b>
	<b>HAZARD WARNING!</b>	<b>XI</b>
	<b>SAFETY</b>	<b>XIII</b>
	<b>DYNAMP, LLC CUSTOMER SUPPORT &amp; SERVICE ASSISTANCE</b>	<b>XIV</b>
	<b>MANUAL REVISIONS</b>	<b>XVII</b>
<b>1.</b>	<b>HANDLING AND STORAGE</b>	<b>1</b>
<b>2.</b>	<b>PRODUCT DESCRIPTION</b>	<b>3</b>
2.1	OVERVIEW	3
2.2	METERING UNIT	3
2.3	INTERCONNECT (TRUNK) CABLE	4
2.4	ELECTRO-OPTIC COMPENSATION MODULE	4
2.5	SENSING FIBER LOOP	4
2.6	HEAD STRUCTURE	5
2.7	INPUTS	5
2.8	OUTPUTS	5
2.9	OPTIONS	6
2.10	ACCESSORIES	6
<b>3.</b>	<b>PRODUCT SPECIFICATIONS</b>	<b>7</b>
<b>4.</b>	<b>INSTALLATION</b>	<b>9</b>
4.1	HANDLING PRECAUTIONS	9
4.2	GENERAL INSTALLATION CONSIDERATIONS	9
4.3	MEASUREMENT HEAD AND HEAD STRUCTURE	10
4.4	MEASUREMENT HEAD STRUCTURE MOUNTING METHODS	11
4.5	ELECTRO-OPTIC COMPENSATION MODULE MOUNTING METHODS	14
4.6	MOUNTING THE MEASUREMENT HEAD STRUCTURE & ELECTRO-OPTIC COMPENSATION MODULE	16
4.7	METERING UNIT INSTALLATION	18
4.8	METERING UNIT AND COMPENSATION MODULE WIRING	19
4.9	COMMISSIONING – FIBER OPTIC SENSING FIBER LOOP ROUTING & POWERUP	20
<b>5.</b>	<b>TROUBLESHOOTING AND SERVICE</b>	<b>23</b>
5.1	ADVANCED ACCURACY DIAGNOSTICS (A2D)	23
5.2	ROUTINE MAINTENANCE	25
5.3	CALIBRATION INTERVALS	26
5.4	SPARE PART REPLACEMENT	26
5.5	RECOMMENDED SPARE PARTS	26

<b>6. THEORY OF OPERATION .....</b>	<b>29</b>
6.1 OVERVIEW .....	29
6.2 TECHNOLOGY DESCRIPTION .....	29
6.3 COMPONENT DESCRIPTION .....	30
<b>7. RELATED TECHNICAL BULLETINS .....</b>	<b>33</b>
<b>8. DRAWINGS .....</b>	<b>35</b>
<b>APPENDIX A : .....</b>	<b>37</b>
<b>APPENDIX B : .....</b>	<b>43</b>

**FIGURES, FORMS & TABLES**

<b>Figure # Title .....</b>	<b>Page</b>
Figure 4-1. Typical LKCO Measurement Head Structure .....	11
Figure 4-2. Mounting Methods .....	11
Figure 4-3. Corner Notch Mounting on a Horizontal Bus .....	12
Figure 4-4. Wall, Bulkhead or Surface Mounting .....	12
Figure 4-5. Mounting on a Vertical Bus using Bus Brackets .....	13
Figure 4-6. Bus Suspension Mounting on a Horizontal Bus .....	14
Figure 4-7a. Remote Electro-optic Compensation Module - T-Section Mounted in Corner .....	15
Figure 4-7b. Remote Electro-optic Compensation Module T-Section Mounted on Side .....	15
Figure 4-8. Electro-optic Compensation Module Integrated with Head Structure .....	16
Figure 4-9. Sensing Fiber Pull Tape Attachment .....	21
Figure 4-10. Installing Ferrule Into Toroid .....	21
Figure 5-1. Optical Subrack Status LEDs .....	23
Figure 5-2. Power Amp Subrack Status LEDs .....	24
Figure 6-1. LKCO System Diagram .....	30
Figure A.1. Improper handling of a pigtailed device. ....	38
Figure A.2.* Worn connectors must be rejected. ....	39
Figure A.3.* Scratched connectors must be rejected. ....	39
Figure A.4. Connector End Face Cleaner .....	39
Figure A.5.* Cleaning Fiber Ends .....	40
Table 3.1 LKCO System Specifications .....	7
Table 5.1 Minimum Spare Parts List .....	27
Table 5.2 Other Spare / Replacement Parts List .....	27
Table 7.1 Technical Bulletin List .....	33
Table 8.1 Drawing List .....	35



## INTRODUCTION

### Safety Precautions and Hazard Warning

Hazardous electric voltage is applied to the Metering Unit terminal blocks for the main power supply input. Remove power from the Metering Unit before accessing these terminal blocks.

LKCO electronic modules contain components that are sensitive to electrostatic discharge (ESD) and should be protected against such hazard. All electronic modules described in these manuals are to be handled while wearing properly grounded anti-static wrist straps.

For information about chemicals and other materials used in the installation of fiber-optic cables, refer to the corresponding Material Safety Data Sheet from the supplier.

### About this Manual

This manual is intended primarily for personnel who install, operate or service the LKCO Series Fiber Optic High Current Measurement System in the field. Detailed descriptions of the LKCO system and subsystems, detailed specifications, installation instructions, troubleshooting and service instructions and theory of operation are presented.

### Related Documentation

The complete set of documentation consists of this manual, applicable drawings and test results.

**This Page is Intentionally Blank**

## HAZARD WARNING!



GENERAL

All installation, maintenance and service must be performed by qualified technicians who are familiar with the warnings and instructions of this manual.

The enclosure doors must remain closed at all times during operation to ensure safety of personnel. A set of keys is provided for locking the door. Only authorized personnel or technicians should be allowed to open and service the unit.

Disconnect power to the system before servicing or replacing fuses.

Use of the equipment in a manner not specified by the manufacturer can impair the protection provided within.

DynAmp does not assume liability for the customer's failure to comply with the rules and requirements provided in this manual.



HAZARDOUS  
VOLTAGE

This equipment is designed to be connected to hazardous electric voltages. Ignoring the installation precautions and warnings can result in severe personal injury, death or equipment damage.

To avoid the risk of electrical shock or fire, the safety instructions and guidelines in this manual must be followed. The electrical specifications must not be exceeded and the unit must be installed according to directions provided. For mounting considerations that fall outside the recommended specifications provided in this manual, the factory should be contacted for approval.

This unit is rated for installation category III and pollution degree 2.



INSTALLATION

This equipment is intended for indoor use only. It should be mounted in a well-ventilated area, away from high heat, dust, and corrosive atmosphere. The ambient temperature must not exceed specified limits.

For mounting considerations that fall outside the recommended specifications provided in this manual, the factory should be contacted for approval.

This unit is rated for installation category III and pollution degree 2.

Symbol Identification:



General definitions of safety symbols used on equipment and in manual.  
Caution/Warning: Refer to accompanying documents for instructions.



The CE mark proves the compliance of the equipment with the requirements of the directives.

**This Page is Intentionally Blank**

## SAFETY

This equipment is designed to be installed to hazardous electric voltages and mounted on high current, high voltage busbars. Ignoring the installation precautions and warnings can result in severe personal injury, death, or equipment damage. The following are general guidelines to be followed during installation, operation and service of the system.

- The nominal weight of the Metering Unit is 70 kilograms (154 pounds). Care must be taken in lifting and installing the Metering Unit. Two people are required to safely lift and properly install the Metering Unit.
- All installation, maintenance and service must be performed by qualified technicians who are familiar with the warnings and instructions of this manual.
- Always follow all local and plant safety instructions.
- Units are not intrinsically safe. Do not place in explosive atmospheres.
- The enclosure door(s) must remain closed at all times during operation to ensure safety of personnel. A set of keys is provided for locking the door(s). Only authorized personnel or technicians should be allowed to open and service the unit.
- Disconnect power to the system before servicing or replacing fuses. Replace fuses with the same type and size as originally supplied with the system. Failure to do so will result in intermittent operation and premature failure. Do not bypass fuses or circuit breakers or modify the electronics.
- Disconnect power to the Metering Unit before installation or servicing.
- The thermostatically controlled heater option is factory set at 5°C. Do not change the factory setting.
- Service must be performed by qualified technicians only. If use of an oscilloscope becomes necessary during servicing, the scope must be floating and not grounded. If a grounded scope is used, a hazardous condition is created since current will flow through the probe to ground.
- Use of the equipment in a manner not specified by the manufacturer can impair the protection provided.

DynAmp, LLC does not assume liability for the customer's failure to comply with the rules and requirements provided in this manual.

**This Page is Intentionally Blank**

## DYNAMP, LLC CUSTOMER SUPPORT & SERVICE ASSISTANCE

For further assistance, contact DynAmp Customer Support at:

Americas:

Telephone: +1 614.871.6900

Fax: +1 614.871.6910

8:00 AM to 5:00 PM USA Eastern Time

From first Sunday in November to second Sunday in March – 13:00 GMT to 22:00 GMT

From second Sunday in March to first Sunday in November – 12:00 GMT to 21:00 GMT

After Hours Critical Service Emergency:

Telephone: +1 614.871.6906

5:00 PM to 8:00 AM USA Eastern Time

From first Sunday in November to second Sunday in March – 22:00 GMT to 13:00 GMT

From second Sunday in March to first Sunday in November – 21:00 GMT to 12:00 GMT

Central e-mail:

[help@dynamp.com](mailto:help@dynamp.com)

DynAmp web:

[www.dynamp.com](http://www.dynamp.com)

**This Page is Intentionally Blank**



## MANUAL REVISIONS

Page	Revision	Reason For Revision	Date
All	NEW		01/08
35, 43	A	ECO 3210 Update Dwg list – add 109099 / Appendix B	02/09
xii, 3, 5, 8, 9, 21, 23, 26, 27	B	ECR 1523 / PAR 10245 – Update Tables 5.1 & 5.2, etc. Add Handling and Storage	08/09
9, 11-20, 43	C	ECR 1549 - update Section 4 Product Specifications, Section 5 Installation, and Appendix B	02/10
6, 7, 21, 22, 27, 28, 37	D	ECO 3246 includes ECR 1574 & 1592 - update section 3.5 “radius” change to “diameter”, add DC Power option drawings, etc.	01/11
9,10, 12, 21, 25, 27, 29 , 45,46	E	ECO 3255 – 4. Change wording on input specification & note, 5.3 additional statement, 5.7 add 3 & 4 ¶ and table, revise 6.1.2, Add 6.1.5, Table 6.1/Fan filter, update Appendix B	05/12
25-27, All	F	ECR 1785 – reference to Maintenance LEDs/ Reformat Manual	10/14
7,9	G	ECR 2057 – 2.8 add A <sup>2</sup> D output, 3.0 add A <sup>2</sup> D spec in Outputs Section	06/16
III, XV, 35	H	ECR 2256 – Update Warranty verbiage, Customer Service and Table 8.1 revisions	05/19

**This Page is Intentionally Blank**

# 1. HANDLING AND STORAGE

DynAmp products are engineered and manufactured for use in industrial environments. However, they contain sensitive electronic and mechanical components which may be damaged and fail if not handled and stored properly. All products must be handled and stored with the same care as any precision measurement instrument. Severe bumps or jolts may damage internal parts and cause malfunction or premature failure. DynAmp products are designed and assembled with conformal coating, shock mounting, and environmental seals, when appropriate or when specified. However, this protection requires that the product must be properly installed and operational before the protection is fully functional. Therefore, adequate protection from humidity, shock, and temperature must be provided during handling and storage prior to installation.

The handling and storage of equipment must be sufficient to meet the storage temperature and humidity specifications of the product and to prevent any condensation or contact with water or any other liquid. The storage location and container or crate must provide adequate protection from precipitation (rain, snow, ice) and direct water contact. Adequate shelter must be provided to prevent the accumulation of precipitation (rain, snow, ice) and water which can lead to the deterioration or failure of shipping containers or crates and cause water ingress. Storage in coastal or industrial areas subject to salt-laden or corrosive air or areas of wind-driven sand or other abrasive dust must be adequate to prevent the deterioration or failure of shipping containers or crates and cause ingress. Frequent inspection of storage areas and storage containers or crates is required to ensure proper storage conditions are being maintained.

If the shipping container or crate is opened and/or the equipment is removed for inspection prior to installation, the equipment must be repackaged in the original undamaged container or crate in the same manner as it was shipped to prevent environmental damage or placed in a storage location that meets the required environmental and storage conditions.

General product storage temperature and humidity requirements:

Storage Temperature:   -40 to 70° C  
                                  -40 to 158° F

Storage Humidity:        Maximum 60%, non -condensing

DynAmp, LLC does not assume liability for the customer's failure to comply with handling and storage requirements.

For further assistance, contact DynAmp customer support.

**This Page is Intentionally Blank**

## 2. PRODUCT DESCRIPTION

The DynAmp LKCO Series Fiber Optic High Current Measurement System represents a significant breakthrough in high current measurement technology. Advanced optical technology senses the phase shift in light caused by the magnetic field from the bus current when the fiber optic sensor encircles a current carrying bus. LKCO is a highly accurate, highly linear current measuring system capable of measuring ac and dc bus currents up to 600 kA.

### 2.1 OVERVIEW

The DynAmp LKCO Fiber Optic High Current Measurement System includes five major components – Metering Unit, Interconnect (Trunk) Cable, Electro-optic Compensation Module, Sensing Fiber Loop, and Head Structure. Several options and accessories are also available and are supplied when specified. Every LKCO model includes the Advanced Accuracy Diagnostics (A<sup>2</sup>D) feature.

### 2.2 METERING UNIT

The LKCO Metering Unit is housed in an IP54 steel enclosure finished with textured light grey polyester powder paint inside and outside. The enclosure includes a clear polycarbonate window in the door so that all LKCO displays and indicators can be easily viewed without opening the enclosure door. Locking latches with matching keys are included.

The Metering Unit is fully assembled and wired and includes the LKCO Optical Subrack, LKCO Power Subrack with Electro-optic Compensation, the LKCO Power Panel, a vent panel, and space for factory installed options and accessories.

The Optical Subrack includes an optical sensor module and an optical status card. The optical sensor module contains a light source and circuitry to derive a current measurement from the polarization changes caused by the current under measurement. The optical status card includes continuous self-diagnostic capability and provides a visual indication of the performance of the optical processing system, as part of the Advanced Diagnostics (A<sup>2</sup>D) feature.

The Power Subrack includes a power supply, a temperature compensation module, and a power amplifier. The power supply provides regulated power to all system electronics, including the Optical Subrack and all factory installed options and accessories. The temperature compensation module continuously monitors critical temperature points in the system enabling the appropriate compensation. The power amplifier acts as the feedback amplifier for the closed-loop compensation system. The subrack also provides a visual indication of the performance of the power supply, temperature compensation module, and power amplifier as part of the Advance Accuracy Diagnostics (A<sup>2</sup>D) feature.

The Power Panel includes a combined circuit breaker / power switch for the metering unit electronics, including the subracks; an additional combined circuit breaker / power switch when the system is configured with the optional cooling fan and/or heater environmental extension(s), and an additional combined circuit breaker / power switch when the system is configured with the optional air conditioner environmental extension. It also includes digital panel meters when the system is configured with the optional on-board current display output or custom energy information display outputs.

The enclosure can be wall mounted with or without wall mount brackets or floor mounted with a pedestal. Wall mounting brackets are provided as a standard. The floor mount pedestal is optional.

Refer to outline and mounting reference drawings at the end of this manual. For information on installing the Metering Unit, refer to the section in this manual titled "Installation."

## 2.3 INTERCONNECT (TRUNK) CABLE

Standard Interconnect (Trunk) Cables are supplied with each system such that the distance between the Metering Unit and the Electro-optic Compensation Module is approximately 30 meters (98 feet). Longer cable lengths are available as an accessory. Contact DynAmp for more information about custom cable lengths. Each cable set consists of one multi-conductor electrical cable and one single fiber optical cable. Each of the individual conductors in the electrical cable is tagged with a numeric label corresponding to the respective terminal block connections in the Metering Unit and the Electro-optic Compensation Module, providing for easy hook-up to the Metering and compensation module. The optical cable is permanently connected at the compensation module and is provided with an optical connector for connection in the Metering Unit.

Care must be taken in the handling of the optical cable and the optical connector. For information on handling optical cable and connectors, refer to the section in this manual titled "Appendix A: Optical Fiber Cleaning and Handling Instructions" and "Appendix B: Cable, Fiber, and Conduit Table."

Refer to interconnection diagrams reference drawings at the end of this manual. For information on installing the Interconnect (Trunk) Cable, refer to the section in this manual titled "Installation."

## 2.4 ELECTRO-OPTIC COMPENSATION MODULE

The Electro-optic Compensation Module contains the optical phase modulator and electro-optic compensation coil. The Electro-optic Compensation Module is packaged in an IP65 molded fiberglass enclosure with a light grey finish inside and outside. It can be configured to be installed as part of the Head Structure or mounted separately near the Head Structure. The Sensing Fiber Loop begins and terminates at the Electro-optic Compensation Module. The Interconnect (Trunk) Cable also terminates in the Electro-optic Compensation Module.

Refer to outline and mounting reference drawings at the end of this manual. For information on installing the Electro-optic Compensation Module, refer to the section in this manual titled "Installation."

## 2.5 SENSING FIBER LOOP

The Sensing Fiber Loop extends from the Electro-optic Compensation Module around the current carrying bus and back to the Electro-optic Compensation Module. It consists of an optical sensing fiber encased in a rugged 6 mm polyethylene jacket.

The Sensing Fiber Loop can be handled and installed per standard practices for dealing with optical fiber cable. The Sensing Fiber Loop is installed in the Head Structure for protection and support at the time the system is installed.

The Head Structure is designed and must be installed such that it maintains a minimum bend radius on the Sensing Fiber Loop of 15 cm (6"), and it must enclose within the loop only the bus and no other metal structures that might carry current not to be included in the measurement.

The Optical Sensing Fiber is drawn with very high levels of uniformity, which allows it to be insensitive to placement around the bus. As long as it is installed with a closed loop around the bus, it does not matter where within the loop the bus is located. Similarly, any nearby bus or magnetic field will have no effect on the measurement as long as it is not enclosed by the Sensing Fiber Loop. This allows installation with maximum flexibility and no need for modeling of the bus and magnetic field

## 2.6 HEAD STRUCTURE

The Head Structure provides protection and support for the Sensing Fiber Loop. The Head Structure typically consists of (8) half-corner sections to complete a total of (4) full corners and up to 8 straight circular tube sections. The Electro-optic Compensation Module may be installed as part of the Head Structure. The Head Structure may be installed utilizing one of four different approaches – corner notch (standard); wall, bulkhead, or surface (standard); bus bracket (optional); or bus suspension (optional).

For more information on installation of the Head Structure and details on these options, refer to the section in this manual titled "Installation."

## 2.7 INPUTS

The following are the inputs, including mains power supply:

- Bus Current: to +/- 600kA
- Mains Power: 95 to 264Vac @ 47 to 63Hz
- An optional DC Mains Supply is available

For more information on inputs refer to the section in this manual titled "Product Specifications."

## 2.8 OUTPUTS

The following outputs are provided as standard:

- Current: 1A full scale : 30kA through 100kA systems  
4mA per kA : over 100kA systems
- Voltage: 10mV per kA : 30kA through 100kA systems  
1mV per kA : over 100kA systems
- A<sup>2</sup>D : Diagnostics Alarm Contact Closure

Note: The LKCO system output takes about 7.5 seconds before it stabilizes upon power up due to system initialization. The output is available about 1.75 seconds after power up, but then resets after 4.5 seconds, for a period of 1.2 seconds before starting up again.

For more information on outputs, refer to the section in this manual titled "Product Specifications."

## 2.9 OPTIONS

LKCO options include:

### 2.9.1 OUTPUTS

The following outputs are available as options:

- Low level current – isolated: 0 to 20mA or 4 to 20 mA full scale
- Voltage: 1V full scale
- High level voltage – isolated: 0 to +/- 10V full scale
- Frequency – isolated: 10kHz full scale; NPN 24V, PNP 24V, or TTL 5V
- Modbus network
- Profibus network
- Digital display – 3.5 digit LED

All output options are factory installed, configured, calibrated, and tested. For more information on optional outputs, refer to the section in this manual titled “Product Specifications.”

### 2.9.2 ENVIRONMENTAL EXTENSIONS

The following environmental extensions are available as options:

- Thermostatically controlled cooling fan
- Thermostatically controlled heater
- Thermostatically controlled cooling fan and heater combination
- Thermostatically controlled air conditioner
- Sealed Air Conditioner

The optional thermostatically controlled heater is factory set at 5°C. Do not change the factory setting. Personal injury or permanent equipment damage may result if the factory setting is changed.

All environmental extensions are factory installed, configured, and tested.

For more information on options, refer to the section in this manual titled “Product Specifications.”

### 2.9.3 FLOOR STAND

Pedestal mount for Metering Unit. The pedestal is supplied with hardware for secure attachment to the Metering Unit and requires installation to a solid base with hardware supplied by the user at the time of installation.

## 2.10 ACCESSORIES

LKCO accessories include:

Custom Interconnect (Trunk) Cable length: The standard Interconnect (Trunk) Cable length is 30 meters (98 feet).

Extended Burn-in: Extended burn-in periods are available in 24-hour increments. The standard burn-in time is 4 hours.



### 3. PRODUCT SPECIFICATIONS

**Table 3.1**  
**LKCO System Specifications**

<b>INPUTS</b>		
	Bus current	Up to +/- 600 kA full scale depending on specific LKCO model
	Span	0% to 110% of full scale <sup>1</sup>
<b>OUTPUTS</b>		
Standard :	Current	1A full scale : 30kA through 100kA systems 4mA per kA : over 100kA systems
	Burden Voltage	5V Maximum
	Voltage	10mV per kA : 30kA through 100kA systems 1mV per kA : over 100kA systems
	A <sup>2</sup> D	Alarm Contact Closure. Form B (NC), Failsafe <b>Dry</b> contact rated 1A max, 250Vac, 30Vdc
Optional :	Low level current	0 to 20mA or 4 to 20mA full scale; isolated
	Voltage	1V full scale
	High level voltage	0 to +/- 10V full scale; isolated
	Frequency	10kHz full scale; isolated; NPN 24V, PNP 24V, or TTL 5V
	Digital / network	Modbus RTU or TCP Network Profibus Network
	Digital display	3.5 digit LED ; internal, remote AC, remote DC
Accuracy :		±0.1% of measurement From 10% to 100% of full scale
Repeatability :		±0.02% of measurement
Linearity :		±0.1% of full scale
<b>MAINS</b>		
Input :	Standard AC	95 to 264 Vac at 47 to 63Hz
	Optional DC	100 to 264 Vdc
	Load	950VA maximum with heater option 350VA without options
<b>Isolation ( Hi-Pot tested at 60Hz )</b>		
	Head to output / metering unit chassis	6.0kVac for 1 minute
	Power supply input to output	1.5kVac for 1 minute
	Power supply output to metering unit chassis	1.5kVac for 1 minute

**Table 3.1  
LKCO System Specifications (Continued)**

<b>Environmental</b>		Operating / Storage
Measurement Head Structure – Sensing Fiber Loop :	IP65	-40° to 70°C / -40° to 70°C -40° to 158°F / -40° to 158°F
Electro-optic Compensation Module :	IP65	-40° to 70°C / -40° to 70°C -40° to 158°F / -40° to 158°F
Metering Unit and Opto-electronics :	IP54	-10° to 50°C / -40° to 70°C 14° to 122°F / -40° to 158°F
Below -10°C (14°F) requires heater		
Above 30°C (85°F) requires fan		
Above 40°C (104°F) requires air conditioner		
<b>Physical</b>		
Head Structure		Modular, sized to bus (10cm x 10cm cross-section)
Color		
Corner Sections		Yellow RAL 1021
Tube Sections		Medium Grey RAL 7042
<b>Electro-optic Compensation Module</b>		
		44cm w x 39cm h x 17cm d 17.3in w x 15.3in h x 6.7in d
Color		Light Gray ANSI 70
Weight		18 kg (40 pounds)
<b>Metering Unit</b>		
		61cm w x 77cm h x 54cm d 24.0in w x 30.3in h x 21.3in d
Color		
Enclosure		Textured Light Grey RAL 7035
Subrack / Panels		Metallic Medium Grey RAL 9006
Weight		70 kg (154 pounds)
<b>Connection</b>		
Power Supply inputs and Signal outputs		Screw terminals
Metering Unit to Electro-optic Compensation Module		30m ( 88 ft. ) cable standard, black Screw terminals on connector in Metering Unit
<b>Pedestal</b>		
		91.5cm ( 36 in. ) height
Color		Medium Grey RAL 7012
Weight		70 kg (154 pounds)

Specifications are subject to change without notice.\*

**Notes :**

1 – In some applications the measurement span may be limited to a lower value.

## 4. INSTALLATION

### 4.1 HANDLING PRECAUTIONS

LKCO systems are intended for use in industrial environments. However, they should be handled with the same care as any precision measurement instrument. Severe bumps or jolts to the Metering Unit, Compensation Module, and Head Structure may cause movement or damage of internal parts, and possibly a malfunction or premature failure. Personnel involved in the installation should be experienced with equipment of similar form and function, and should also be familiar with the technical terms, warnings, and instructions in this manual, and all plant safety rules, and be able to follow these.

The complete system should be inspected for shipping damage at the earliest opportunity. Visible damage must be reported to the carrier immediately. Concealed damage (not evident until the system is operated) must be reported to DynAmp, LLC immediately.

The LKCO Measurement Head is shipped in partially assembled sections. These sections are joined together during installation.

<b>CAUTION</b>
Always use care in handling the Sensing Fiber cable. Do not sharply bend the Sensing Fiber cable or apply great tension, as permanent damage will occur.
The fiber optic Sensing Fiber Loop and fiber optic Interconnect (Trunk) Cable are permanently connected inside the Compensation Module. They are delivered coiled inside the Compensation Module for protection. They should remain coiled in the Compensation Module until the time each is individually routed to its position as described in the following sections.

#### 4.1.1 UNPACKING THE EQUIPMENT

Before unpacking any equipment, inspect the exterior packaging for visible damage incurred during transit. Remove the outer wrapping or packaging. Check all items against the packaging list. If damage is suspected during shipping and handling, contact DynAmp, LLC Customer Support.

### 4.2 GENERAL INSTALLATION CONSIDERATIONS

The LKCO Measurement Head is composed of an Electro-optic Compensation Module, a fiber optic Sensing Fiber Loop, a fiber optic Interconnect (Trunk) Cable and a Head Structure consisting of corner forms, conduit sections, and couplings to support and position the Sensing Fiber Loop.

Familiarize yourself with the components in the kit and the proposed installation location. Determine the direction of the conventional current flow in the primary bus.

#### 4.2.1 INSTALLATION CONSIDERATIONS FOR HEAD STRUCTURE

Read the following considerations before mounting the Head Structure.

Choose a mounting location where the ambient air temperature does not exceed 70°C. The standard Head Structure is designed for indoor or outdoor use. The Head Structure is rated IP65, which stipulates the following characteristics:

- Protection from electrical shock as hazardous voltages are inaccessible
- Limited ingress of dust into the enclosure
- Limited ingress of water into the enclosure via dripping, spray, or jets from any direction

The Head Structure should NOT be submerged under water at any time.

The Head Structure must be installed with current arrows pointing in the same direction as conventional current flow in the bus. Each arrow indicates the direction that conventional bus current must flow through the aperture (+ to -). No damage will occur if the Head Structure is reversed, but the system will produce a negative output.

<b>WARNING</b>
Always follow applicable local and plant safety instructions when installing the LKCO System.

Before installing the Head Structure on the bus, check the Head Structure sections and components to make sure that no internal damage occurred during shipment. This is accomplished by fitting the individual Head Structure sections together to test fit and determine that all necessary parts are present. The Head Structure does not need to be mounted on bus for the fit check. After the fitting is complete, the Head Structure should be mounted as explained in the following sections.

### 4.3 MEASUREMENT HEAD AND HEAD STRUCTURE

The LKCO Measurement Head consists of an Electro-optic Compensation Module, including permanently attached fiber optic Sensing Fiber Loop and fiber optic Interconnect (Trunk) Cable. The Head Structure supports the fiber optic Sensing Fiber Loop and includes PVC corner forms, PVC conduit sections, and PVC couplings. The PVC components are supplied in partially assembled sections. The sections are joined together on-site to encircle the busbar(s). After the physical installation of the Head Structure components, the fiber optic Interconnect (Trunk) cable is routed to the Metering Unit.

During the commissioning phase, the Sensing Fiber Loop is threaded through the Head Structure PVC corner forms, conduit sections, and couplings, as a final step. This supports, protects, and positions the Sensing Fiber Loop. To facilitate threading the Sensing Fiber Loop through the Head Structure, the PVC corner forms can be split apart temporarily by removing the fastening screws. For outdoor installation, after the Sensing Fiber Loop is installed properly and proper operation verified, it is recommended that silicone RTV be applied to the internal mating walls to help seal against water ingress.

The Electro-optic Compensation Module may be remote mounted on a wall or other support structure close to the Head Structure, or integrated as part of the Head Structure.

Familiarize yourself with the components, installation method, location, and conditions. Determine the direction of the conventional current flow in the primary bus. If bulkhead / wall mounting is to be used, acquire four suitable wall anchors, bolts, and spacers to attach the Electro-optic Compensation Module to the wall or support structure. If the Electro-optic Compensation Module is to be freestanding, procure the required mounting hardware. The structure supporting the compensation module and clearance must be sufficient for proper installation.

**IMPORTANT NOTE:**

Use extreme care manipulating the Sensing Fiber Loop. Do not sharply bend the sensing fiber loop or apply great tension, as permanent damage will occur.

Determine if solvent will be used to join the conduit couplings to the conduits. This is required to produce an IP65 rating. The mating surfaces of the conduit and corners must be abraded to remove the existing paint for solvent joining. PVC pipe cleaner and PVC solvent cement are not provided with the LKCO system. These materials must be procured locally.

The orientation of the Electro-optic Compensation Module must be determined prior to installing the mounting hardware. Proper polarity must be observed for the system to work properly. Conventional current flows through the Head Structure from positive to negative. Apply the right-hand-rule. With the current flowing in the direction of the thumb, the end of the Sensing Fiber Loop is inserted in an anti-clockwise direction through the Head Structure. One additional hole must be cut, drilled, or punched in the Compensation Module enclosure for the conduit to carry the electrical and fiber optic Interconnect (Trunk) Cables to the Metering Unit electronics enclosure.

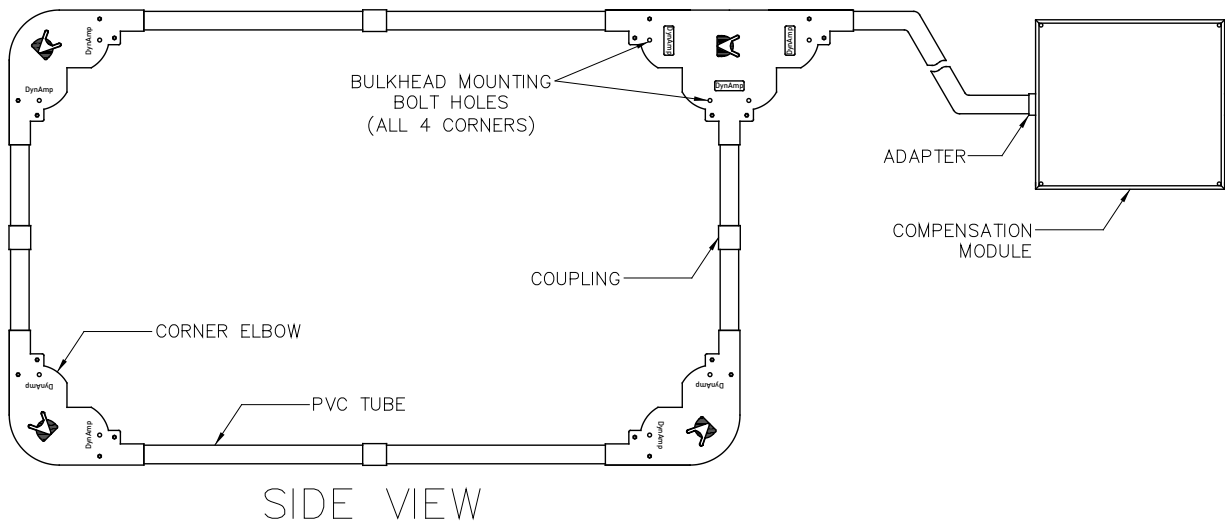

**Figure 4-1. Typical LKCO Measurement Head Structure**

### 4.4 MEASUREMENT HEAD STRUCTURE MOUNTING METHODS

The Head Structure can be installed vertically or horizontally. There are several methods possible for mounting the Head Structure. The appropriate mounting scheme for each LKCO system must be specified on the LKCO Product Worksheet when the system is ordered. Recommended methods for mounting the Head Structure include:

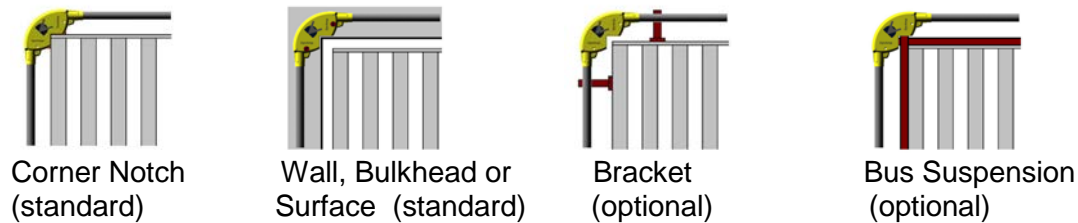
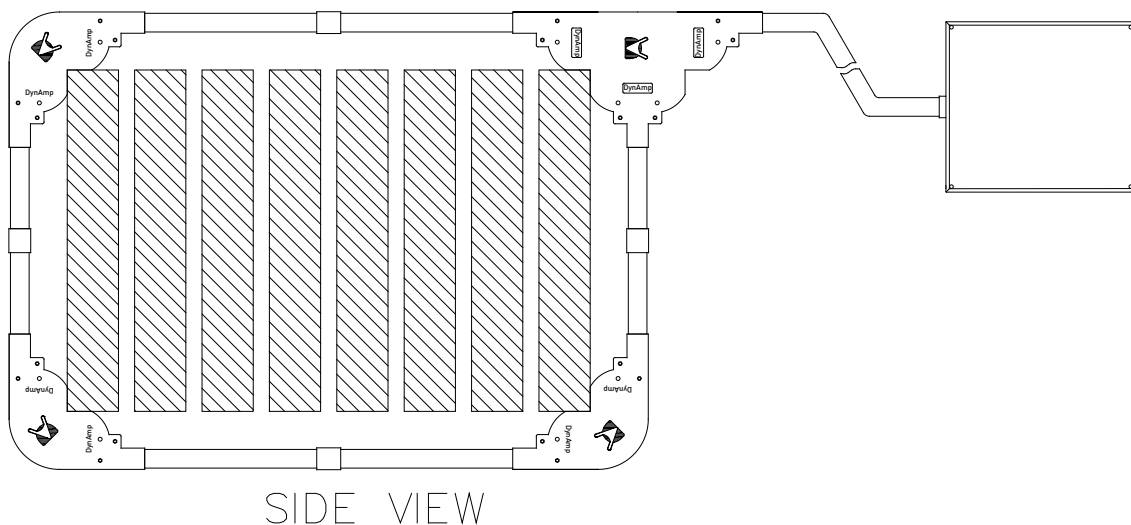

**Figure 4-2. Mounting Methods**

Descriptions and figures for each of the Head Structure mounting methods are shown below. The Electro-optic Compensation Module can be remote mounted near the Head Structure (preferred) or integrated with the Head Structure (alternate). The descriptions and figures below show a remote mounted Compensation Module.

### 4.4.1 CORNER NOTCH

The interior of Head Structure corner form elbows rest on the corners of the busbar(s). This may be used for horizontal (running) busbar orientations or vertical (rising) busbar orientations if additional supports are used. The busbar temperature must be less than 90°C to use this mounting technique. (See Figure 4-3)



**Figure 4-3. Corner Notch Mounting on a Horizontal Bus**

### 4.4.2 WALL, BULKHEAD OR SURFACE MOUNTING

The Head Structure is bolted directly to a wall, bulkhead, or the surface of a support structure. If the Electro-optic Compensation Module is integrated in the Head Structure, spacers may be used to offset the Head Structure from the support structure, allowing clearance for the compensation module. This method may be used for vertical (rising) or horizontal (running) busbar(s). (See Figure 4-4)

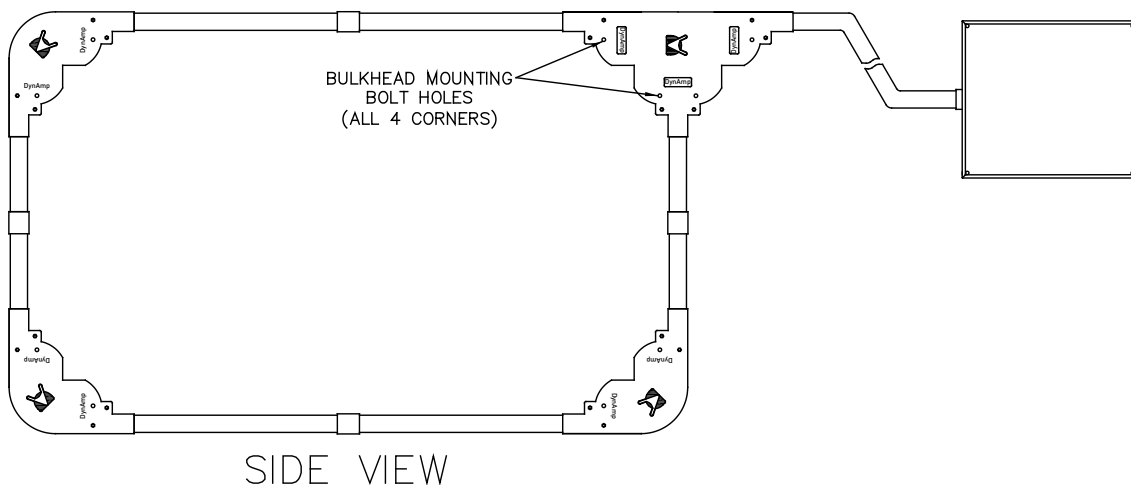

**Figure 4-4. Wall, Bulkhead or Surface Mounting**

### 4.4.3 BUS BRACKET MOUNT

The optional bus brackets may be screwed directly to the busbar (or other support structures) using self-tapping screws. This method may be used for vertical (rising) or horizontal (running) busbar(s). (See Figure 4-5)

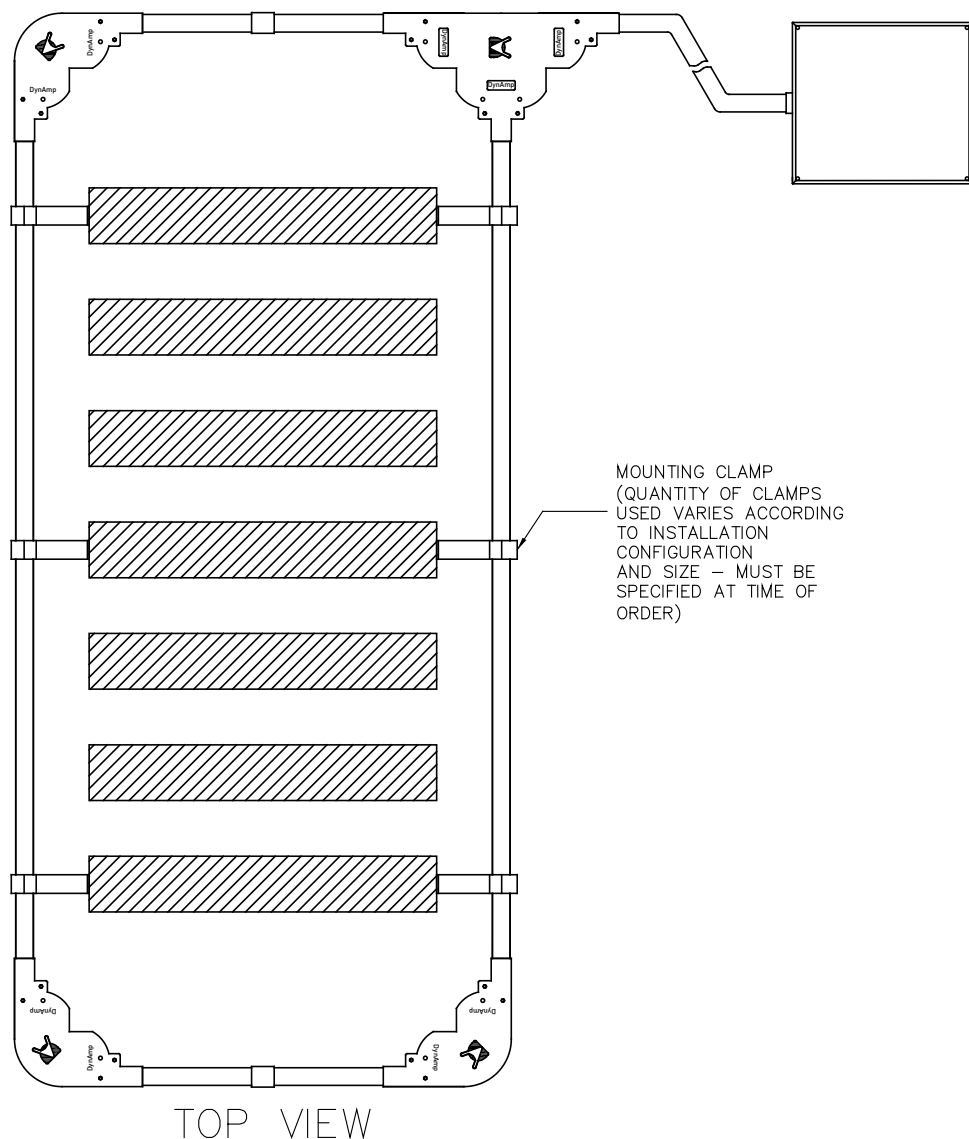

**Figure 4-5. Mounting on a Vertical Bus using Bus Brackets**

### 4.4.4 BUS SUSPENSION MOUNT

Fiberglass bar stock pieces are fastened inside the Head Structure corner form elbows. The fiberglass bars rest on the busbar(s) to support the Head Structure. For some applications, multiple “frames” made of fiberglass bars may be bolted together and inside the corner form elbows. The bus suspension mount method may be used for horizontal (running) busbar orientations or vertical (rising) busbar(s) if additional supports are used. (See Figure 4-6)

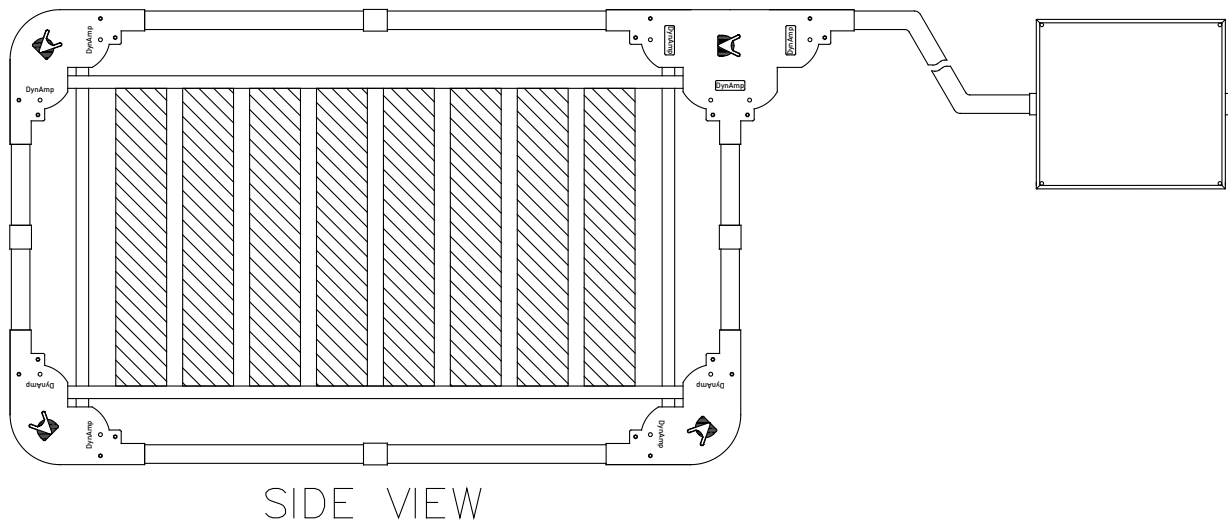

**Figure 4-6. Bus Suspension Mounting on a Horizontal Bus**

## 4.5 ELECTRO-OPTIC COMPENSATION MODULE MOUNTING METHODS

In general, the electro-optic Compensation Module can be installed vertically or horizontally. There are several methods possible for mounting the compensation module. The appropriate mounting scheme for each LKCO system must be specified on the LKCO Product Worksheet when the system is ordered. Recommended methods for mounting the Electro-optic Compensation Module include:

- Remote mounted near Head Structure (Shown in the figures in the previous section)
- Wall, bulkhead, or surface mount
- Integrated with the Head Structure

Descriptions and figures for each of the Electro-optic Compensation Module mounting methods are shown below.

### 4.5.1 REMOTE ELECTRO-OPTIC COMPENSATION MODULE

This is the recommended method for mounting the Electro-optic Compensation Module.

This method may be used in combination with any of the methods for mounting the Head Structure corner form elbows, conduit, and couplings discussed above. The Electro-optic Compensation Module is mounted close to, but not integrated as part of the measurement Head Structure. The user is responsible for ordering or providing the mounting hardware and support structure for the compensation module in this mounting scheme. (See Figure 4-7a and 4-7b)



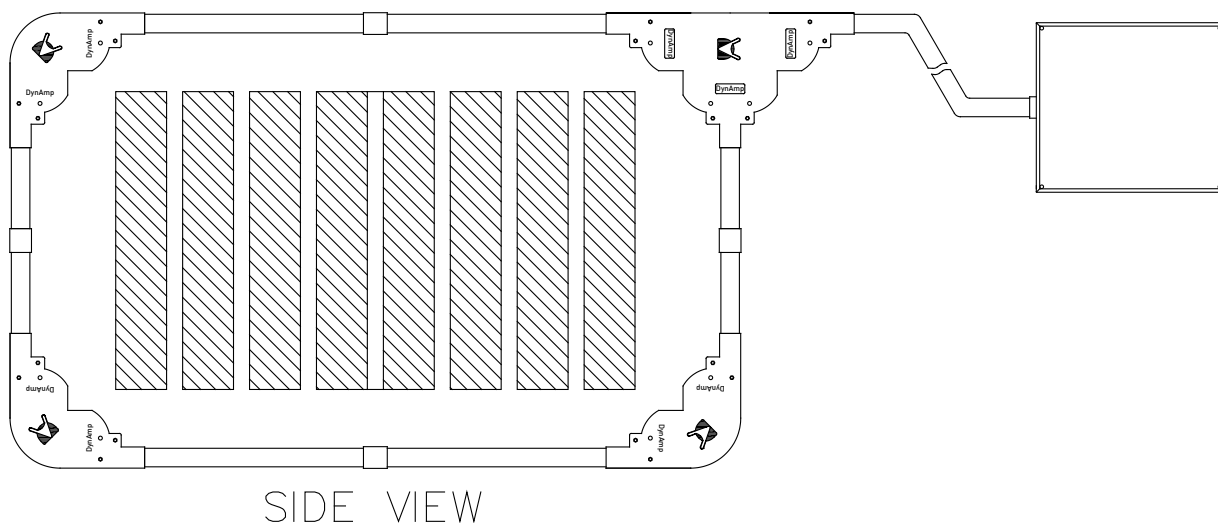

**Figure 4-7a. Remote Electro-optic Compensation Module - T-Section Mounted in Corner**

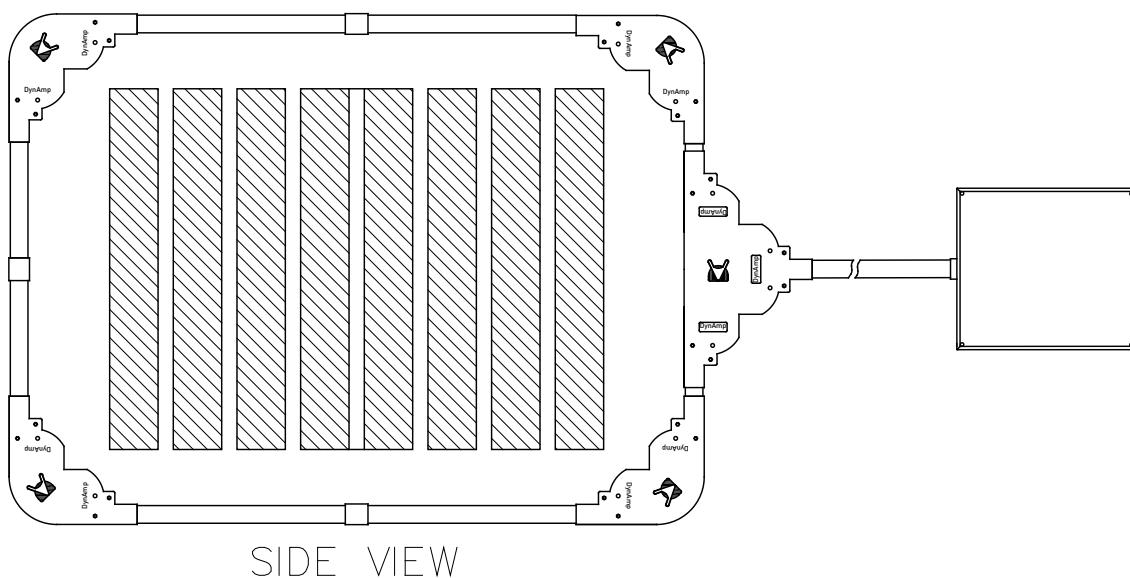

**Figure 4-7b. Remote Electro-optic Compensation Module T-Section Mounted on Side**

### 4.5.2 ELECTRO-OPTIC COMPENSATION MODULE INTEGRATED WITH HEAD STRUCTURE

This method may be used in combination with any of the methods for mounting the Head Structure corner form elbow, conduit and couplings discussed above. The Electro-optic Compensation Module is integrated as part of the measurement Head Structure. The user is responsible for ordering or providing the mounting hardware and support structure for the compensation module in this mounting scheme. (See Figure 4-8)

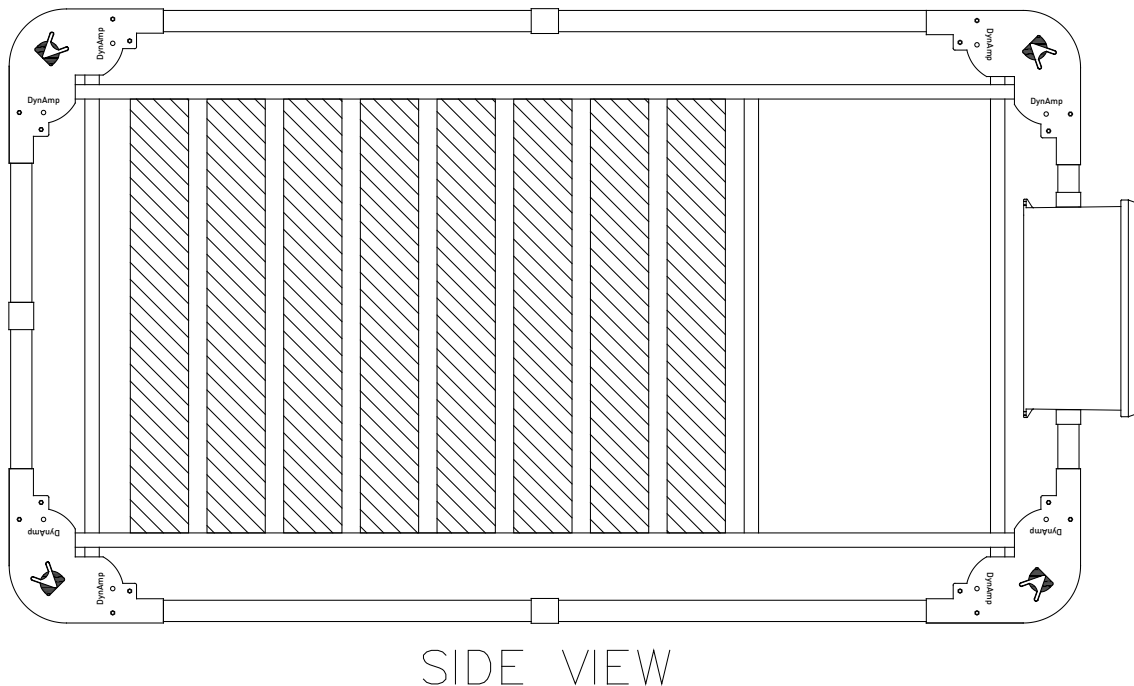

**Figure 4-8. Electro-optic Compensation Module Integrated with Head Structure**

## 4.6 MOUNTING THE MEASUREMENT HEAD STRUCTURE & ELECTRO-OPTIC COMPENSATION MODULE

### 4.6.1 HEAD STRUCTURE TEST FIT CHECK

Lay out all structural components on the ground and place the components in the appropriate positions protecting the finish with a clean, soft surface.

1. Assemble the parts of the Head Structure in the order listed below:

Top half of Head Structure

- 1.) Left half shell corner form & conduits
  - 2.) Right half shell corner form & conduits
  - 3.) Top center conduit coupling
  - 4.) Horizontal (long) fiberglass bar (bus suspension option)
  - 5.) Vertical (short) fiberglass bars (bus suspension option)
  - 6.) Spacer (shortest –100 mm) fiberglass bars which goes between the half shells and the vertical bars (bus suspension option)
  - 7.) Cap screws
  - 8.) Flat head screws
  - 9.) Loosely tighten the hardware until after the entire sensor support assembly has been installed on the bus.
2. Allow the corner forms to remain open until after the Sensing Fiber Loop has been inserted.

3. Place the assembled top half of the sensor support structure on the bus.
4. Using the right and left vertical and spacer fiberglass bars and hardware (bus suspension option), attach the bottom right and left corner forms, conduits and couplings.

## 4.6.2 HEAD STRUCTURE AND COMPENSATION MODULE INSTALLATION

<b>IMPORTANT NOTE:</b>
Conventional current flow (positive to negative) is assumed. The Sensing Fiber Loop must encircle the busbar according to the right-hand-rule. With the conventional current flowing in the direction of the thumb, the sensor cable end is to be inserted in an anti-clockwise direction through the Head Structure.

The following steps apply to all mounting methods:

1. Refer to the appropriate Outline & Mounting drawing at the end of this manual.
2. Lay out all Head Structure components on the ground and place the components in the appropriate positions protecting the finish with a clean, soft surface.
3. Determine the proper orientation of the electro-optic Compensation Module for proper polarity. This determines the direction the Sensing Fiber Loop is threaded through the Head Structure.
4. Re-assemble the Head Structure. Ensure that conduit ends are bottomed out in the couplings.
5. Use a pen, pencil, or piece of tape to mark the point on the outside of the conduit (adjacent to the coupling) to indicate proper seating depth (bottoming out) of conduit in coupling cavity.
6. Remove paint on the outside part of PVC conduits that will be glued into coupling cavities. (This area of the tube is indicated by the markings made during the previous step.)
7. Determine position where the conduit for Interconnect (Trunk) Cable and fiber optic Interconnect (Trunk) cables from the electro-optic Compensation Module will enter the compensation module.
8. Drill, punch, or cut the hole in the desired position in the compensation module enclosure taking great care to protect the components and fiber optic cables inside.
9. Move the Head Structure components and hardware to the installation point on the busbar(s).
10. Determine the proper order of assembly for sections of the Head Structure and compensation module (based on the busbar location and other physical structures).
11. Make provisions to structurally support (or counter-balance) the electro-optic Compensation Module during the joining operation.
12. Use PVC cleaner to clean the surfaces to be joined.
13. Place pre-assembled sections of the Head Structure around the busbar(s) and use PVC cement to join the corner forms, conduits, couplings and Electro-optic Compensation Module (if integrated with the Head Structure) to encircle busbar(s). Conduit tubes must be "bottomed out" in coupling cavities to ensure proper fit.

14. Temporarily install a pull tape through the Head Structure to assist in threading the Sensing Fiber Loop at a later point.

### **BUS SUSPENSION MOUNTING ONLY:**

Refer to reference drawing "Outline and Mounting LKCO Measuring Head" at the end of this manual.

1. Place the assembled top half of the Head Structure on the bus.
2. Using the right and left vertical and spacer fiberglass bars and hardware, attach the bottom right and left corner forms, conduits and couplings.
3. Use screws to attach fiberglass bars inside of Head Structure elbow halves. Let the corner forms remain open until after the sensor cable has been inserted. **DO NOT INSTALL THE FINAL HEAD STRUCTURE ELBOW HALF-SHELLS AT THIS TIME.**
4. Loosely tighten the hardware until after the entire Head Structure has been installed on the bus.
5. Place the assembled top half of the Head Structure on the bus.
6. Using the right and left vertical and spacer fiberglass bars and hardware, attach the bottom right and left corner forms, conduits and couplings.
7. Fasten the bottom and the top of the head structure to the bus or adjacent structure to prevent movement caused by wind, vibration, or other forces.

### **BUS BRACKET MOUNTING ONLY:**

Refer to reference drawing "Outline and Mounting LKCO Measuring Head" at the end of this manual.

1. Determine the position of the mounting brackets on the busbars.
2. Drill holes in busbar(s).
3. Use self-tapping screws to mount bottom half of bracket assembly to busbar(s).
4. As head is assembled and glued together, use remaining self-tapping screws to mount top half of bracket assembly around the PVC conduit. Loosely tighten the hardware until after the entire Head Structure has been installed on the bus.
5. Observing the proper polarity, install the electro-optic Compensation Module in the proper mounting location. If bulkhead / wall mounting is used, mark the locations for the mounting hardware on the support bulkhead or wall. Procure necessary mounting hardware such as wall anchors, standoffs, or drill and tap the bolt anchors.
6. Install the electro-optic Compensation Module on the conduit of the bulkhead / wall. Insert the bottom conduits into the preinstalled conduit fittings. Square the assembly and, being careful, tighten all bolts.
7. Temporarily install a pull tape through the Head Structure to assist in threading the Sensing Fiber Loop at a later point.

## **4.7 METERING UNIT INSTALLATION**

The location of the Metering Unit should be determined by the following factors:

1. An indoor location should be selected where the clean ambient air temperature is within -10°C to +30°C at all times.

2. For ambient temperatures less than -10°C, an optional heater is required. For ambient temperatures between +30°C and +40°C, an optional fan is necessary. For temperatures greater than +40°C some form of active cooling is required.
3. Allow a minimum of 10” (25cm) of free space on the vent side of the enclosure for proper ventilation.
4. If the optional fan is installed and to ensure proper air circulation, all openings in the enclosure must be closed, except for the intake and exhaust grills. With wall mount installation, the bottom plate on the enclosure must be attached. Conduit openings added to the enclosure should be blocked to prevent air escape through the conduits (use putty or loose insulation material – do not apply pressure on the fiber optic Interconnect (Trunk) Cable).
5. The location should be a minimum distance from high current busbars per the table below. Standard system location should be within reach of the head cable length to be routed (30 meters or 98 feet). Special cable lengths up to 150 meters (492 feet) may be ordered. Anchor the cabinet in the desired location after ensuring adequate cable reach.

LKCO Model	Busbar Current (kA)	Minimum Recommended Distance to Busbar (meters)
LKCO-60 thru LKCO-100	60 – 100	4
LKCO 130 thru LKCO-400	130 – 400	7
LKCO-400 thru LKCO-600	400 – 600	9

6. The enclosure must be located such that the door can be fully opened and that qualified technicians can have access to circuit breaker(s) / power switch(es) located on the internal Power Panel.

The optional thermostatically controlled heater is factory set at 5°C. Do not change the factory setting. Permanent equipment damage may result if the factory setting is changed.

## 4.8 METERING UNIT AND COMPENSATION MODULE WIRING

1. Route the multi-conductor electrical Interconnect (Trunk) Cable and the fiber optic Interconnect (Trunk) Cable from the Electro-optic Compensation Module to the Metering Unit. When routing, great care must be taken to prevent any high ‘pulling’ forces that can strain and damage the fiber optic Interconnect (Trunk) Cable, particularly concerning the optical connector. Additionally, make sure all possible precautions are taken to keep the connector clean. Avoid bending the optical fiber sharply, to prevent breakage. Always clean the fiber optic connectors before final connection is made with the coupling during installation. Please refer to Appendix A for instructions on cleaning. A small splice box is provided to store the bulkhead coupling and fiber optic connectors inside the metering unit. Attach the box to the right inner side of the enclosure wall with the provided double-sided tape.
2. Refer to the interconnection diagrams at the end of the manual
3. Terminate all electrical conductors from the Compensation Module as shown in the interconnection diagrams. As an aid to wiring, each conductor is identified by a numbered sleeve (or imprinted numeral), which corresponds to the correct terminal destination. If the wire ends get damaged and require re-stripping, use high quality wire strippers and set the strip length to 0.39” (10mm).

4. Note: No external ground connection or any connection other than the supplied multi-conductor electrical Interconnect (Trunk) Cable should be made to the Compensation Module, to preserve electrical isolation.
5. Install and connect the output-monitoring devices to the appropriate terminals at the Metering Unit. If the current loop output is used, remove the factory-installed jumper and connect the current loop as required. Be sure to use adequate wire size. Make sure that the burden imposed by the wire is not excessive.
6. Complete the wiring by connecting the external power lines to terminals in the Metering Unit. The Metering Unit includes a 10-ampere supplementary circuit breaker to protect the system electronics and an additional 10-ampere circuit to protect the heater if the heater is an included option. Use conductor and circuit protection sized adequately for 900VA power requirement. The wire should have a minimum insulation rating of 300Vac and 80-105° C. Installing a 15-ampere branch protection circuit breaker is recommended for the power circuit supplying this unit. Local codes may vary, so follow local codes.
7. When DC power is used to supply the metering unit, the wiring diagram for the DC Power Option is followed. The DC power supplies the electronics and optional outputs only. It does not supply the environmental options (heater or cooling fan). If those options are installed, a separate AC power source is required. The fan and heater operate at either a nominal 115Vac or 230Vac, specified at the time the system is ordered.

## 4.9 COMMISSIONING – FIBER OPTIC SENSING FIBER LOOP ROUTING & POWERUP

After the Head Structure and Electro-optic Compensation Module are installed, the final LKCO commissioning steps can be performed

<b>IMPORTANT NOTE:</b>
------------------------

LKCO Commissioning should only be performed by personnel with specific experience and training to prevent permanent damage to the fiber optic Sensing Fiber Loop and ensure its installation does not adversely affect measurement accuracy.
--

The following provides the user with a general overview of the Commissioning process.

The Electro-optic Compensation Module is opened and the fiber optic Sensing Fiber Loop is carefully uncoiled and inspected. The end of the Sensing Fiber Loop is then carefully attached to the pull tape (pilot tape or fish tape) running through the Head Structure being extremely careful to avoid putting tension on the end ferrule. Tape the pull tape to the nylon jacket of the Sensing Fiber Loop beyond the aluminum tube and to the red stop marker. Do not shift the position of the red stop marker on the sensing fiber jacket (see Figure 4-9).

The Sensing Fiber Loop is then installed by gently pulling the pull tape while simultaneously gently pushing the Sensing Fiber Loop into the other end of the conduit. The Sensing Fiber Loop is routed through the entire Head Structure with the corner form elbow assemblies open, ultimately returning the ferrule end back into the Electro-optic Compensation Module to complete the loop around the bus bar.

Excess fiber optic sensing fiber cable is gathered and carefully coiled so that it will fit inside the Compensation Module. The ferrule end of the Sensing Fiber Loop is then carefully inserted in the gland on the toroid until the front edge of the red stop marking is flush with the opening in the cable gland as shown in Figure 4-10. The excess fiber optic sensing fiber cable is loosely attached to the top of the toroid. Great care must be taken to avoid bending the Sensing Fiber

Loop too sharply or attaching the excess coiled sensing fiber cable too tightly to the top of the toroid.

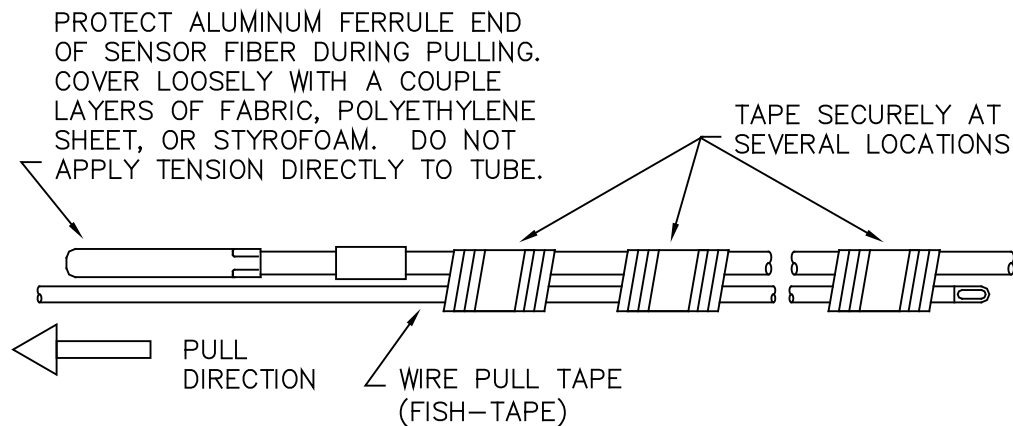

**Figure 4-9 Sensing Fiber Pull Tape Attachment**

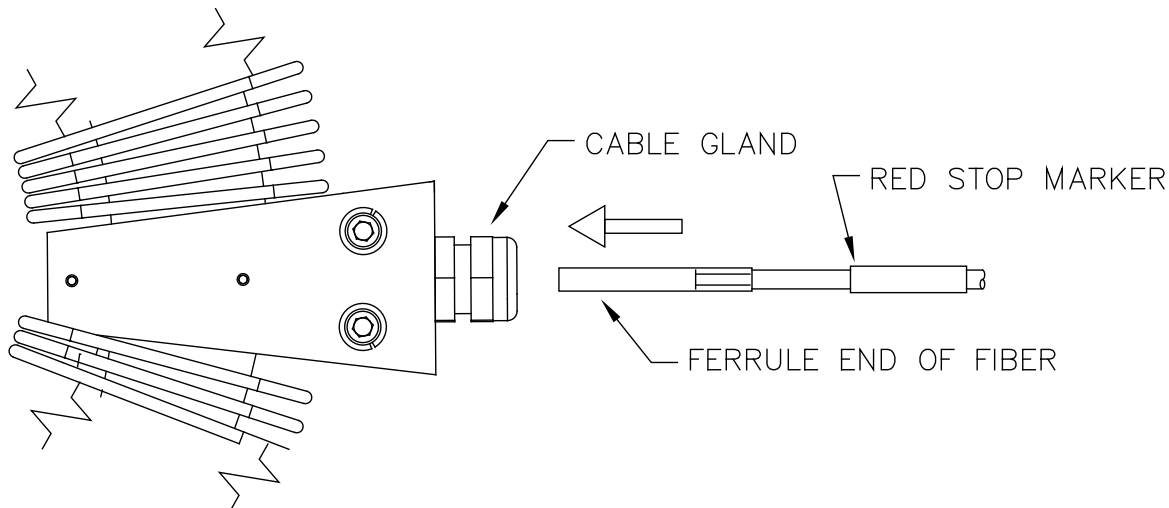

**Figure 4-10. Installing Ferrule Into Toroid**

Once the Sensing Fiber Loop is correctly installed, the Corner Form Elbow sections of the Measurement Head Structure are closed. This is performed by running a bead of RTV sealant along the edge of each corner elbow cavity that encloses the sensing fiber cable. The corner form halves are then bolted together using the supplied hardware. RTV is also used to seal all other mating surfaces and unused through-holes in the corner forms.

Mains voltage and frequency are checked before any power is applied to the system. If the LKCO is equipped with a system heater, the heater is switched on at least 30 minutes before the LKCO system is powered up. If the temperature is above +30 C, the LKCO should be equipped with a system fan, which should preferably be switched on 30 minutes before the LKCO system is powered up.

A laptop with commissioning software is connected to monitor the system performance during the commissioning process. The LKCO system is now powered on. A complete set of data is saved to record the as installed parameters. LKCO front panel indicator lights are checked for status. If the Maintenance Required and/or the Invalid Data alarm LEDs are on, the commissioning

software on the laptop is utilized to identify the cause of the alarm as well as verify that any corrective actions were successful.

'Cold' bus (zero current) system output checks are performed after the system has been powered up for 30 minutes. This includes checking standard current and voltage outputs as well as any optional isolator current, isolator voltage, isolator frequency and or digital outputs.

Before connecting the signal outputs to plant electronics, the plant electronics are checked to ensure they are compatible with LKCO signals regarding resistance, impedance, grounds, etc.



## 5. TROUBLESHOOTING AND SERVICE

### 5.1 ADVANCED ACCURACY DIAGNOSTICS (A<sup>2</sup>D)

LKCO includes an Advanced Accuracy Diagnostics (A<sup>2</sup>D) feature that continuously monitors system operation and performance to enhance measurement confidence, notifying the user of specific system installation, operation, performance, or developing problems or faults.

#### 5.1.1 LKCO OPTICAL SUBRACK STATUS INDICATORS

The overall status of the optical electronics is displayed on the front panel of the Optical Subrack with three LEDs - Power, Maintenance Required, and Data Invalid as shown in Figure 5-1.

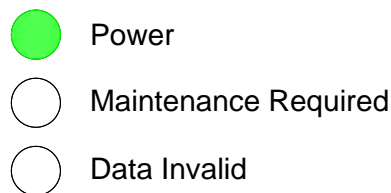

**Figure 5-1. Optical Subrack Status LEDs**

In normal operation, the Power LED is “ON” and both the Maintenance Required LED and Data Invalid LED are “OFF.”

#### 5.1.2 LKCO OPTICAL SUBRACK ALARMS

- **Power** : If the power LED is off, it indicates an internal failure in the Optical Subrack or a loose power connection on the back of the Optical Subrack. This condition requires immediate attention.
- **Maintenance Required** : This alarm usually indicates a condition that requires attention, but usually does not degrade accuracy. Causes are usually due to a dirty optical connector, partial light path restriction due to pressure or a tight bend on the fiber-optic interconnect, or perhaps loose cable wiring. Some issues may be repaired during the next scheduled maintenance.
- **Data Invalid** : This alarm usually indicates a condition that requires immediate attention. The system may be unstable or lose accuracy (exception in cases of fan startup alarm, mentioned in Note below). Causes are usually due to severe restriction of the light path due to pressure or tight bend on the fiber-optic interconnect , or perhaps disconnected cable wiring. Internal failure of the electronics or power supply, are also possible.

**NOTE**

A Maintenance Required alarm in the Power Subrack will trigger a Maintenance Required in the Optical Subrack. A fan failure or slow fan start within the Power Subrack will trigger the Data Invalid alarm only. If the Optical Subrack has a “Data Invalid” alarm only shortly after power up and no other indicator alarms are on either subrack, then do the following once or twice: switch the LKCO unit off for 5 seconds and apply power again. If after initialization the “Data Invalid” alarm does not go away, then contact DynAmp LLC for assistance.

### 5.1.3 LKCO POWER SUBRACK STATUS LEDs

The overall status of the power electronics is displayed on the front panel of the Power Subrack with four LEDs - Power, Maintenance Required, Compensation Overrange, and Temperature Sensor. The status LEDs are shown in Figure 5-2.

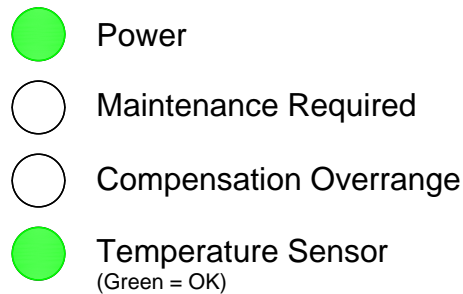

**Figure 5-2. Power Amp Subrack Status LEDs**

In normal operation, the Power LED (green) is “ON,” the Maintenance Required LED is “OFF,” the Compensation Overrange LED is “OFF,” and the Temperature Sensor LED (green/red) is “ON GREEN.”

### 5.1.4 LKCO POWER SUBRACK ALARM SEQUENCES

1. System initialization sequence:

Power	On – Green
Maintenance Required	On
Compensation Overrange	On
Temperature Sensor	Flash – Red/Green (8 rapid) Flash – Red/Green (6 slow) Flash – Red/Green (8 rapid)

If no alarm condition was detected during system initialization, the normal operation sequence will be set. Otherwise, the appropriate alarm sequence will be set.

2. Normal operation:

Power	On – Green
Maintenance Required	Off
Compensation Overrange	Off
Temperature Sensor	On – Green

3. Compensation Overrange alarm:

Compensation Overrange	On or flashing – Red
------------------------	----------------------

Immediate maintenance is required. A possible cause may be the wiring between the Metering Unit and the Compensation Module has become disconnected.

4. Temperature Sensor alarm (Case #1):

Maintenance Required	On
Temperature Sensor	On – Green

Maintenance is required at the next scheduled maintenance. This indicates that 1 or 2 temperature sensors have failed resulting in the overall system accuracy being degraded less than approximately 0.1%. Schedule repair of the failed temperature sensors at the next scheduled maintenance.

- 5. Temperature Sensor alarm (Case #2):
  - Maintenance Required            On
  - Temperature Sensor            On – Red

Immediate maintenance is required. This indicates that more than 2 temperature sensors have failed resulting in the overall system accuracy being degraded more than 0.1%. Contact DynAmp, LLC for assistance.

- 6. Temperature Sensor alarm (Case #2):
  - Power                                    Off

Immediate maintenance is required. This indicates that one or more of the internal supplies have failed or are out of range. Contact DynAmp, LLC for assistance.

### 5.1.5 GENERAL TROUBLESHOOTING TIPS

Most “Maintenance Required” alarms and “Data Invalid” alarms will not cause the system to become unstable. Loss of accuracy may occur in some cases. In case of a fault that renders the system output unstable or erratic, it is recommended that the plant control be switched to manual mode or a back-up system until the issue is resolved. It is also recommended that the LKCO System be powered down until further instructions of DynAmp, LLC to prevent further damage to the equipment. This also applies to instances where the power LED on one or both sub racks is extinguished.

In case of an alarm, the first step is generally to download a status report for the LKCO equipment (using a serial cable and desktop or laptop computer) and send the report to DynAmp, LLC for analysis as soon as possible. The software and instructions are available for download from DynAmp, LLC upon request.

## 5.2 ROUTINE MAINTENANCE

As is true with any electronic circuitry, proper maintenance will prolong the service life. DynAmp, LLC recommends the following program be performed at the recommended interval to prevent or detect damage to the LKCO system and to ensure continuing high-accuracy performance. Always use appropriate measures to correct any problems found. Following the suggested maintenance may assist in early diagnosis of problem(s) to minimize repairs and down time.

<b>CAUTION</b>
To avoid the risk of shock and electrocution, always disconnect the power before performing any cleaning or service operation on the metering unit.

Visually inspect fiber-optic connections to ensure they are not loose or dirty. Clean per instructions in Appendix A.

<b>IMPORTANT NOTE:</b>
Keep organized, accurate recorded data (forms, etc.) from each Periodic Maintenance. This information may be invaluable in troubleshooting a malfunctioning LKCO system.

## 5.2.1 CLEANING INSTRUCTIONS

Metering Unit interior (should only be performed after disconnecting power to the metering unit): Dust and dirt can be removed by gently vacuum cleaning the unit. Be careful not to damage the internal shunt. Solvents should never be used on any of the PC boards. The boards may be manufactured with a protective conformal coating that can be stripped away by certain solvents.

If the unit is equipped with a cooling fan and filter, then the filter should be cleaned or replaced at a regular interval in order to maintain adequate cooling airflow. The service life of the filter is dependant on the level of contaminants in the air. Periodic examination to monitor filter loading should be performed. The filter is required to maintain IP 54 (UL12) rating of the enclosure. If the metering unit is installed in a very clean environment, a type 1 reusable foam filter is available. The filter is washable. It also allows higher airflow through the fan, thereby increasing cooling efficiency. The IP rating of the enclosure is 20 (UL1) when the foam filter is used.

## 5.3 CALIBRATION INTERVALS

DynAmp does not specify required intervals of calibration for its products.

The end user of the product is responsible for identifying the appropriate interval between calibrations. The intervals should be determined based on the following factors:

- Requirements of a Quality Management System
- Accuracy and permissible limits of errors
- Purpose and usage
- Experience with similar products
- Manufacturer's recommendations
- Stability of the product
- Past history
- Other characteristics of the product

Reference: "ISO/IEC 17025:2017, General requirements for the competence of testing and calibration laboratories" and Laboratory Accreditation Bureau "Guidance for Documenting and Implementing ISO/IEC 17025:2005 and Laboratory Guidance".

## 5.4 SPARE PART REPLACEMENT

Requests for spare parts should be directed to the Service group at DynAmp, LLC during normal business hours. When contacting us, please present as much information as possible, such as the related equipment Model and Serial Numbers (available on the equipment tag); the required part name; its DynAmp, LLC item number (and other identifying or vendor number(s)); and your time needs. An approved Purchase Order Number should be given with your order.

## 5.5 RECOMMENDED SPARE PARTS

The following table lists the minimum recommended quantities for spare parts for the LKCO. As spares are used, replacements should be ordered. Since continuous operation of high current measurement systems is usually critical, stocking spare parts should be given high priority.

The LKCO System requires special repair instructions and materials. However, the system is very reliable and should require little or no repair over its service life. Please refer to the nearest DynAmp Authorized Service Center for information on repairs.

**Table 5.1  
Minimum Spare Parts List**

DESCRIPTION	ITEM NO.	QUANTITY
* FUSE, 1A 250V Slo-blo MDL , ¼" by 1 ¼" (6.3 mm x 32mm) (5 per box)	012590	1 box
*Replacement Filter, Disposable Type IP54 (UL12) [2 per system]	045559	2

\*Spare parts are used in conjunction with LKCO options

**Table 5.2  
Other Spare / Replacement Parts List**

DESCRIPTION	ITEM NO.
Spare Optical Subrack	045045
Power Subrack	044591
Spare Compensation Module	045043

**This Page is Intentionally Blank**

## 6. THEORY OF OPERATION

### 6.1 OVERVIEW

The DynAmp LKCO Series Fiber Optic High Current Measurement System represents a significant breakthrough in high current measurement technology. Advanced optical technology senses the phase shift in light caused by the magnetic field from the bus current when the fiber optic sensor encircles a current carrying bus. LKCO is a highly accurate, highly linear current measuring system capable of measuring ac and dc bus currents up to 500 kA. The product uses the same core technologies that have been widely used in high voltage alternating current sensors for utility applications and fiber optic gyros for precision navigation applications.

The LKCO is a fiber optic current sensor, which produces a low voltage output in direct proportion to the primary current on the bus. Optionally, this voltage may be converted to a current output using a precision trans-conductance amplifier. LKCO derives its measurement based on the phase shift between two optical signals created by the primary bus current. The system offers many distinct advantages over other types of high current measurement devices including:

- High accuracy, linearity, and stability over temperature.
- Minimal position sensitivity allows the sensor to be placed anywhere around the bus.
- Compact and lightweight design allows ease of installation and maintenance.
- Flexible sensing fiber loop allows mounting on nearly any bus configuration.
- Complete immunity from external magnetic fields permits installation on geometrically complex bus work. There is no need for a DynAmp Bus Evaluation or exact positioning to optimize performance.
- Advanced Accuracy Diagnostics (A<sup>2</sup>D) continuously monitors system operation and performance.

### 6.2 TECHNOLOGY DESCRIPTION

The LKCO optical circuit and signal processing is a close derivative of the fiber optic gyro used in commercial and military products for the navigation of aircraft, spacecraft, and submarines.

The fiber optic current sensor works on the principle of the Faraday effect. Current flowing in a conductor induces a magnetic field, which, through the Faraday effect, rotates the plane of polarization of light traveling in the optical fiber wound around the current carrying conductor. Ampere's Law states that the closed line integral of the magnetic field around the conductor is equal to the current flowing through the conductor. If the sensing fiber is wound around the current carrying conductor with a known integral number of turns and magnetic field sensitivity, then the rotation of the plane of polarization of the light in the optical fiber depends on the current being carried in the conductor and is insensitive to all external magnetic fields, including those resulting from nearby conductors. The phase shift between right-handed and left-handed circularly polarized light waves is measured to determine the electrical current.

Light from the light source passes through a coupler and a depolarizer and then through a polarizer. The polarizer defines the beginning of the interferometric region. Following the polarizer, the light is split into two linearly polarized light waves. These two light waves travel down polarization maintaining fiber until they reach a quarter wave plate. The quarter wave plate converts the linearly polarized light waves to circularly polarized light waves. The quarter wave point defines the beginning of the sensing region and the point where the optical fiber is routed around the current carrying conductor.

In the sensing region, the two circularly polarized light waves maintain their states of polarization. The sensing fiber consists of special spun birefringence fiber with a high spin rate. The two circular waves experience a differential phase shift in the presence of the magnetic field. At the end of the sensing region is a mirror. The mirror causes the light to retrace its path through the optical circuit and reverses the polarization states of the two light waves, right-handed to left handed and left handed to right handed.

On the return trip through the sensing fiber and the optical circuit, the two light waves travel in opposite directions with respect to the magnetic field, but, having the opposite polarization states, they continue to accumulate magnetically induced phase shift. When they reenter the quarter wave plate, the two light waves again become linearly polarized. However, they remain swapped when compared to the polarization state of the light entering the sensing region. The two beams travel back through the polarization maintaining fiber, and through the polarizer where they are interfered. The light then propagates through the coupler to a detector where the impact of the phase shift is measured and the resulting signal is processed.

A patented closed loop “full compensation” system places the entire system, including light source, opto-electronics, optical fiber, signal processing, and measurement output signals, under closed loop control, automatically adjusting for any long term changes in sensitivity, gain, drift, or zero point.

### 6.3 COMPONENT DESCRIPTION

There are three main components to the sensor – Metering Unit Electronics, Electro-optic Compensation Module, and Sensing Fiber Loop. (See Figure 6-1.)

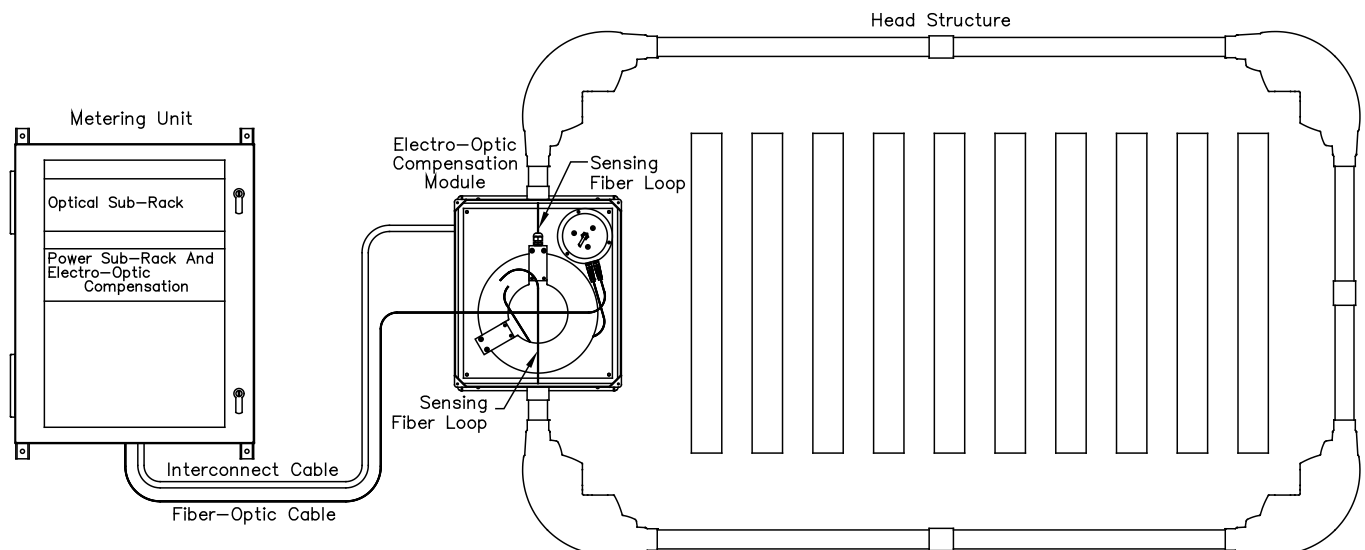

**Figure 6-1. LKCO System Diagram**



### 6.3.1 METERING UNIT ELECTRONICS

The Metering Unit electronics include an Optical Subrack and a Power Subrack with Electro-optic Compensation.

The Optical Subrack electronics provide the intelligence for the sensor. It contains the light source and the circuitry to interrogate the return signals to derive a current measurement from the polarization changes caused by the current under measurement. The Optical subrack features a modular design with an optical sensor module and an optical status card.

The Power Subrack with electro-optic compensation electronics provide a regulated power source for all system electronics, monitor all critical temperature points and provide appropriate compensation, and serve as the feedback amplifier for the closed loop compensation system. The Power Subrack with electro-optic compensation features a modular design with a power supply, a temperature compensation module, and a power amplifier.

The Optical Subrack and the Power Subrack electronics have a continuous self-diagnostic capability and report on possible problems via LEDs and dry contacts for remote annunciation. This is part of the Advance Accuracy Diagnostics (A<sup>2</sup>D) feature.

Installation must be in accordance with the instructions in the section titled "Installation."

### 6.3.2 ELECTRO-OPTIC COMPENSATION MODULE

LKCO utilizes a patented closed loop "full compensation" nulling technique to place the entire system under closed loop control. A current signal is driven from the Metering Unit through multiple wire turns around a multiple fiber turn coil in the sensing region in the opposite direction to the primary current being measured. The product of the current signal, the number of wire turns, and the number of fiber turns is equivalent to the current under measurement. The system adjusts the current signal until the phase shift induced by the primary current is nulled. The Electro-optic Compensation Module contains the electro-optic compensation coil and an optical phase modulator.

Installation must be in accordance with the instructions in the section titled "Installation."

### 6.3.3 SENSING FIBER LOOP

The Sensing Fiber Loop extends from the Electro-optic Compensation Module around the current carrying bus and back to the Electro-optic Compensation Module. It consists of an optical sensing fiber encased on a rugged 6 mm Nylon jacket with Kevlar strength members. The optical sensing fiber is drawn with very high levels of uniformity that allow it to be insensitive to placement around a current carrying conductor. As long as it is installed with a closed loop around the current carrying conductor, it does not matter where within the loop the conductor is located. Similarly, any nearby magnetic field will have no effect on the measurement as long as it is not enclosed by the Sensing Fiber Loop. This allows installation with maximum flexibility and eliminates the need for modeling of bus and magnetic fields.

Installation must be in accordance with the instructions in the section titled "Installation."

**This Page is Intentionally Blank**

## **7. RELATED TECHNICAL BULLETINS**

**Table 7.1**  
**Technical Bulletin List**

**This Page is Intentionally Blank**

## 8. DRAWINGS

**Table 8.1**  
**Drawing List**

DRAWING TITLE	NUMBER	REVISION
Outline & Mounting LKCO Metering Unit Pedestal Mount	02B108844	A
Outline & Mounting LKCO Compensation Box	02B108851	B
Interconnection LKCO System	02B109162	A
Wiring Diagram LKCO Metering Unit	83B109043	B
Wiring Diagram LKCO Metering Unit Options	83B109044	D
Wiring Diagram LKCO Profibus – DP Option	83B109099	B
Wiring Diagram LKCO – DC Power Option	83B109192	A
Interconnection LKCO System with DC Power Option	02B109193	-
Outline & Mounting LKCO Metering Unit Wall Mount	02B108913	A
Outline, LKCO Air Conditioner	02B108990	-

**This Page is Intentionally Blank**

# APPENDIX A:

## OPTICAL FIBER CLEANING AND HANDLING INSTRUCTIONS

### 1.1 OVERVIEW

Before any connections are made, fiber-optic cables and connectors should be cleaned. This appendix provides standard instructions that are intended to prevent damage to the cables, including methods of handling and cleaning optical fiber connectors, optical fiber, and optical fiber components.

These instructions will be updated as new tools and methods are developed and new components are used in DynAmp products.

### 1.2 SAFETY REQUIREMENTS

No special safety requirements arise from this appendix other than the safe handling of the cleaning fluids, isopropyl alcohol and acetone. Electrostatic Discharge (ESD) precautions should be strictly adhered to because opto-electronic components are very sensitive to ESD. ESD procedures should be used when handling opto-electronic modules.

### 1.3 HANDLING OPTICAL FIBER

Many fiber-optic products incorporate fiber pigtail interfaces between the optical device and the optical connector. These fiber pigtails are extremely fragile and must be handled carefully to avoid breakage. Knots, kinks, twists and sharp bends in the optical fiber will ruin the fiber's ability to transmit light or, for polarization maintaining fiber (PM), maintain its polarization properties. In many cases, a bend or break in an optical fiber will completely disrupt the system's performance. Dangling even an insubstantial weight from the end of a fiber can break or irreparably damage the fiber pigtail.

Never pull a fiber cable by the connector, always use a strain relief member of the cable or pull sock to pull a fiber through a conduit or raceway. Make sure the raceway does not have sharp corners or protrusions that could damage the cable. The cable should be pulled off the reel in a linear motion not a circular motion. Allowing the fiber to be pulled off the reel in a circular motion puts twist into the cable, which will cause kinks and snags when trying to pull into a conduit.

Never use the fiber to pick up or support the weight of the device to which it is attached as shown in Figure A.1 Improper handling of a pigtailed device. Instead, always keep both the device and the optical connector together in your hands.

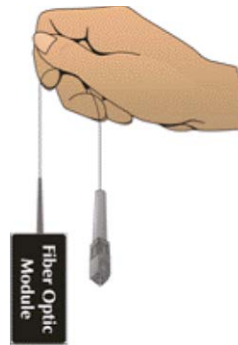

**Figure A.1. Improper handling of a pigtailed device.**

Do not allow kinks or knots to develop in the fiber. Carefully work out any tangles. Pulling on the fiber will cause any kinks or curls to tighten and exceed the minimum bend radius of the fiber, and result in a break.

Do not force the fiber into retaining clips. First open the clips, slip the fiber carefully inside, and close the clips, ensuring the fiber is not caught in the clip latch.

## **1.4 HANDLING AND CLEANING OPTICAL FIBER CONNECTORS**

### **1.4.1 Connecting and Disconnecting Connectors**

Before working with the connector, always clean the connector ferrule and end face. Damaging dust cannot always be seen. For cleaning instructions, refer to the next section “Cleaning Optical Interfaces.” To insert the connector into the receptacle of the module, hold the back narrow part of the connector and push it straight in until it stops. Tighten the locking nut finger tight or set the latch.

To disconnect, loosen the locking nut or release the latch. Hold the front wide part of the connector and pull straight back until the connector is free.

Because of the tight tolerances on the connector, the disconnecting process requires some force. If the connector doesn't come out on the first attempt, don't wiggle the connector sideways. This will damage components inside the connector. Instead, hold the module tight at the receptacle and pull straight back.

When inserting a connector ferrule into a connector or adapter, ensure that the ferrule tip does not touch the outside of the mating connector or adapter. Otherwise, scratches and dirt deposits will be placed on the end of the fiber connector. Ceramic and metal sleeves inside the adapter are tightly fitted and excessive dirt will damage both the sleeve and the connector ferrule. When mating the connector to an adapter, carefully rotate the ferrule in the adapter in order to align it with the connector key. Do not force the ferrule into the adapter.

To ensure reliable patch cords, you must carry out the cleaning instruction every time there is a disconnection. The use of protective caps is necessary, but does not guarantee the cleanliness or the quality of a connector.



## 1.4.2 Cleaning Optical Interfaces

To properly carry out connector maintenance, you must be familiar with visual inspection instructions. No dirt or oil should be on the connector end face or fiber core. Any connector with a scratch across the core, or a scratch that appears to end in the core, must be rejected. Any connector with more than one scratch must also be rejected. In addition, any patch cord showing obvious signs of wear on the ferrule, cladding or core must be rejected, see Figure A.2. and Figure A.3.

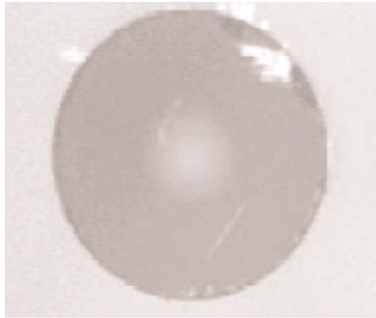

**Figure A.2.\* Worn connectors must be rejected.**

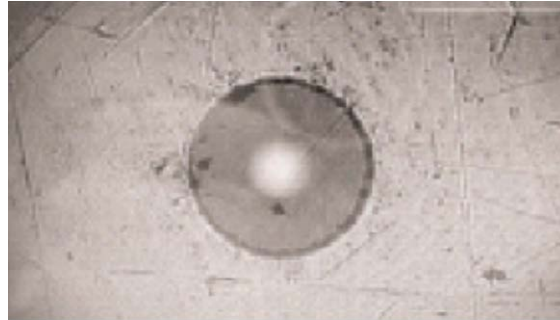

**Figure A.3.\* Scratched connectors must be rejected.**

To insure the correct optical performance, the fiber ends of the end surface of the connector must be cleaned before the connection is made. Cleaning wands with lint-free material are preferred over cotton or foam swabs. The cleaning wand also absorbs less alcohol; reducing the likelihood that alcohol residue will accumulate on the ferrule end surface.

## 1.4.3 Cleaning Fiber Connectors

Connectors are designed to require a minimum of maintenance in order to provide reliable operation over time. To ensure a minimum insertion loss, it is important that fiber ends and optical ports be clean at all times. Proper cleaning also prevents the buildup of dirt, dust and other foreign substances — especially in connector pins. Cleaning connectors is difficult because the core diameter of a single mode fiber measures only about 9 mm. Damaging dust and scratches on the surface cannot be seen without a microscope.

The first approach is shown in Figure A.4. This cleaner is convenient for fieldwork or quick end face cleaning. However, it will not take oil and dirt off of the ferrule, nor will it remove adhesive residue or other material stuck on the end face.

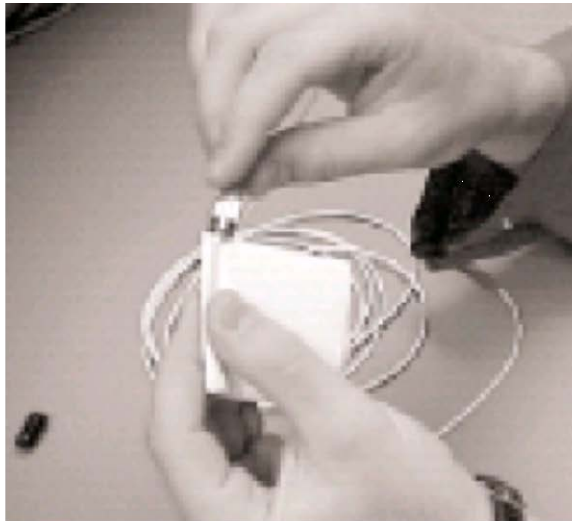

**Figure A.4. Connector End Face Cleaner**

The cleaning equipment required for the second approach includes Isopropyl alcohol (98% pure or more), soft tissues (Kimwipes), cotton swabs (cleaning tips), compressed air (free of dust, water, and oil), and a connector microscope (if available).

The following instruction describes the steps for cleaning a connector end face.

1. Ensure the fiber is not active (that is, there is no light in the fiber).
2. Remove the protective caps.
3. Gently wipe the fiber end with a lint-free cloth moistened with isopropyl alcohol, as shown in Figure A.5.



**Figure A.5.\* Cleaning Fiber Ends**

4. Dry using a lint-free cloth and dry, filtered compressed air.
5. Verify the cleanliness with a microscope. The patch cord is clean when there is no debris on the end face of the connector.

#### 1.4.4 Handling and Cleaning Optical Fiber Components; Splicing

A general instruction is given below for handling and cleaning optical fiber components. For best results, follow the splicing instruction.

1. Strip back the layers of the fiber protection using the following methods:
  - Outer Jacket (Yellow) - Wire Strippers  
Strip 3-4 cm length of the outer jacket with ordinary wire strippers.
  - Kevlar Yarn - Diagonal Cutters (or Utility Knife)  
Cut away Kevlar yarn with special diagonal cutters.
  - Tight Buffer - Microstrip No Nic Strippers  
Strip 3 - 5 cm length of tight buffer.
  - Acrylic Protective Cladding – Fiber-optic Stripper  
Strip a 2 cm length of acrylic cladding with a specialized fiber-optic stripper. Some fiber lacks this soft acrylic cladding; if it is present, you will see white material come off as you strip the fiber.
2. Clean the stripped glass fiber using a Kimwipe dipped in alcohol. If you must re-use the Kimwipe, ensure it is still clean and damp.
3. Cleave the fiber. A good cleave is the key to obtaining a good splice. Follow the specific cleavers instructions for best results.

Place the fiber in the cleaver so the acrylic cladding is at the appropriate mark and so that the glass fiber lies in the groove and crosses the gap. The fiber must lie flat on the support.

Note: There are two different types of cleavers; one where the cut fiber fragment is disposed of automatically, and one where the fiber fragment is loose in the vicinity of the cleave. **IN THE LATTER CASE, IMMEDIATELY LOCATE THE CUT FIBER FRAGMENT AND PLACE IT IN A SUITABLE DISPOSAL CONTAINER.**

Use tweezers or sticky tape to pick up the fragment (NOT your fingers). Fragments can penetrate your flesh and are difficult to remove. Do not risk anyone's safety by leaving fiber fragments lying around.

Clean the fiber with a Kimwipe and alcohol and immediately place it in the fusion splicer. Lower the hold down while ensuring the fiber does not move out of place. Doing this immediately prevents damage to, or dirt accumulation on, the fiber.

4. Splice the fiber. Place the cleaved ends of the fiber in the splicer following the specific splicing instruction for that device.

The splicer will align the fibers and fuse them. From the accuracy of the alignment, the splicer will predict the loss of the splice (0.2 dB or less is typical for a good splice). Repeat this process until a good splice is obtained.

If a protective sleeve is used, slide the sleeve over the splice and then place it with the metal rod at the bottom in the tubing heater.

**This Page is Intentionally Blank**

# APPENDIX B :

## CABLE, FIBER AND CONDUIT TABLE

From	To	Function	Type	AWG	Pairs O.D.	Supplied by	Comments
Electro-optic Compensation Module	Metering Unit	CT Fiber Feeder Cable	Plenum Single mode fiber cable			DynAmp	For details, see section 1.1 of this document
Electro-optic Compensation Module	Metering Unit	PZT- Drive Cable  Temperature Sensor Cable	Belden 1040A  Twisted, individually shielded / overall shielded	16	6 pair  0.682"	DynAmp	Maximum Length = 150m (492ft)  Contact DynAmp, LLC for other lengths  Screw Terminals
Electro-optic Compensation Module	Metering Unit	Conduit for copper and fiber cables	2" nominal conduit minimum size		2"	Customer	
Metering Unit  TB1-20 & 21	External Shunt	Feedback Current loop	Twisted pair  Belden Type 8471 or equivalent	16	1 pair  0.28"	Customer	Maximum Length = 20m (contact DynAmp for other lengths)  Screw Terminals  If shield is used, connect shield to meter unit at far-end
Metering Unit  TB1-22 & 23	Secondary Equipment	mV signal output	Twisted pair  Belden Type 88760 or equivalent  Shielded	18	1 pair  0.153"	Customer	mV output  Maximum Length = 50m  Screw Terminals  Shield connected to DUT Meter Unit at far-end
Metering Unit  See Note 1 below  TB1-26 & 27  TB1-28 & 29	Secondary Equipment	Low level current loop output  0-20mA or 4-20mA (optional)	Belden Type 8761 or equivalent	20 or larger	1 or more depending on number of options	Customer	Maximum length depends on total load  Maximum load (including cable) must not exceed 600Ω

From	To	Function	Type	AWG	Pairs O.D.	Supplied by	Comments
Metering Unit See Note 1 below TB1-24 & 25	Secondary Equipment	High level voltage output : 1..10V	Twisted pair Belden Type 88760 or equivalent  Shielded	18	1 pair 0.153"	Customer	Minimum load : Unbuffered = 1 Megohm Buffered > 2k ohm
Metering Unit TB1-30 & 31	Secondary Equipment	A <sup>2</sup> D Warning Circuit  TB1-30 & 31	Commercial grade  Belden Type 8719 or equivalent cable)  Shielded	16	1 pair 0.313"	Customer	Screw Terminals  Shield grounded at far-end
Metering Unit	Desktop or laptop computer	A <sup>2</sup> D Communication Serial Port	9-pin shielded Serial Extension Cable			Customer	15m maximum length.  Active serial port extenders may be used.  DB9 Male to DB9 female  Do not use Null Modem cable.

Notes:

- 1- Note: Low Level Current and High Level Voltage output terminal numbers may vary slightly (TB1-24 through TB1-29), depending on the number of options ordered. The terminal numbers provided above are typical. Refer to the labeling on the product for correct terminal numbers for installed options.